

PURSUIT®

2470 CENTER CONSOLE OWNER'S MANUAL

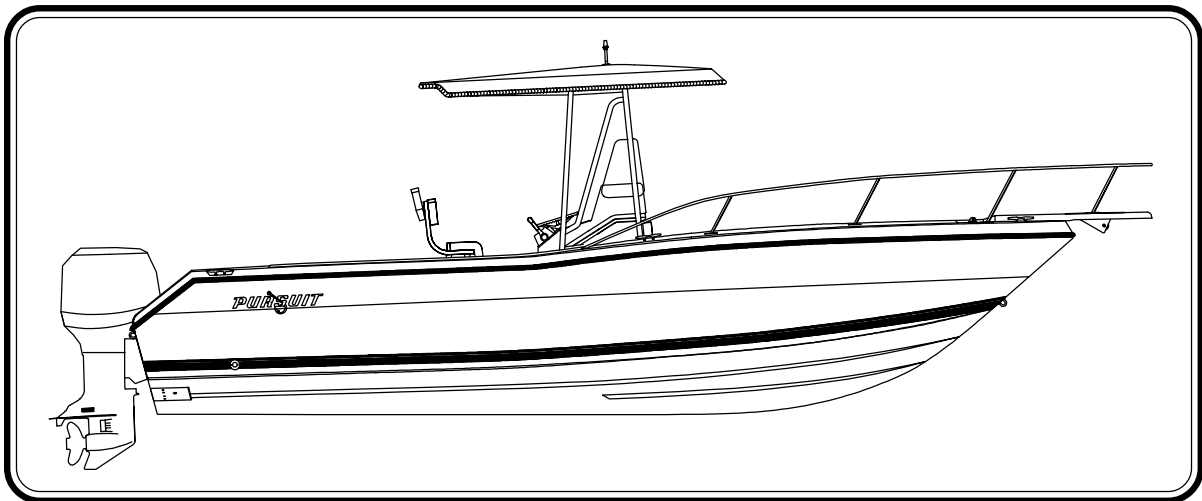

PURSUIT FISHING BOATS
3901 St. Lucie Blvd.
Ft. Pierce, Florida 34946

PURSUIT® 2470 CENTER CONSOLE

Print Date 3/2002

**THIS PAGE WAS LEFT BLANK
INTENTIONALLY**

SAFETY INFORMATION

Your **PURSUIT**® 2470 Center Console Owner's Manual has been written to include a number of safety instructions to assure the safe operation and maintenance of your boat. These instructions are in the form of **DANGER**, **WARNING**, **CAUTION**, and **NOTICE** statements. The following definitions apply:



IMMEDIATE HAZARDS WHICH WILL RESULT IN SEVERE PERSONAL INJURY OR DEATH.



HAZARDS OR UNSAFE PRACTICES WHICH COULD RESULT IN SEVERE PERSONAL INJURY OR DEATH.



HAZARDS OR UNSAFE PRACTICES WHICH COULD RESULT IN MINOR PERSONAL INJURY OR PRODUCT AND PROPERTY DAMAGE.



INFORMATION WHICH IS IMPORTANT TO PROPER OPERATION OR MAINTENANCE, BUT IS NOT HAZARD RELATED.

All instructions given in this book are as seen from the stern looking toward the bow, with starboard being to your right, and port to your left. A glossary of boating terms is included.

IMPORTANT NOTE: Your boat uses internal combustion engines and flammable fuel. Every precaution has been taken by Pursuit Fishing Boats to reduce the risks associated with possible injury and damage from fire or explosion, but your own precaution and good maintenance procedures are necessary in order to enjoy safe operation of your boat.

**THIS PAGE WAS LEFT BLANK
INTENTIONALLY**

BOAT INFORMATION

Please fill out the following information section and leave it in your Pursuit 2470 Center Console Owner's Manual. This information will be important for you and Pursuit service personnel to know, if and when you may need to call Pursuit for technical assistance or service.

| BOAT | |
|---------------------------------------|---------------------|
| MODEL: | HULL SERIAL #: |
| PURCHASE DATE: | DELIVERY DATE: |
| IGNITION KEYS #: | REGISTRATION #: |
| DRAFT: | WEIGHT: |
| | |
| ENGINE(S) | |
| MAKE: | MODEL: |
| PORT SERIAL #: | STARBOARD SERIAL #: |
| | |
| TRANSMISSION(S) (Inboard) | |
| MAKE: | MODEL: |
| PORT SERIAL #: | STARBOARD SERIAL #: |
| RATIO: | |
| | |
| OUTDRIVE(S) (Inboard/Outboard) | |
| MAKE: | MODEL: |
| PORT SERIAL #: | STARBOARD SERIAL #: |
| | |
| PROPELLER(S) | |
| MAKE: | BLADES: |
| DIAMETER/PITCH: | OTHER: |
| | |
| TRAILER | |
| MAKE: | MODEL: |
| SERIAL #: | GVRW: |
| | |
| DEALER | PURSUIT |
| NAME: | PHONE: |
| DEALER/PHONE: | REPRESENTATIVE: |
| SALESMAN: | ADDRESS: |
| SERVICE MANAGER: | |
| ADDRESS: | |
| | |

Pursuit Fishing Boats reserves the right to make changes and improvements in equipment, design and vendored equipment items, at any time without notification.

**THIS PAGE WAS LEFT BLANK
INTENTIONALLY**

IMPORTANT INFORMATION

Warranty and Warranty Registration Cards

The Pursuit Limited Warranty Statement is included with your boat. It has been written to be clearly stated and easily understood. If you have any questions after reading the warranty, please contact the Pursuit Customer Relations Department.

Pursuit, engine manufacturers, and the suppliers of major components maintain their own manufacturer's warranty and service facilities. It is important that you properly complete the warranty registration cards included with your boat and engine(s) and mail them back to the manufacturer to register your ownership. This should be done within 15 days of the date of purchase and before the boat is put into service. A form for recording this information is provided at the beginning of this manual. This information will be important for you and service personnel to know, if and when you may need service or technical information.

The boat warranty registration requires the **Hull Identification Number "HIN"** which is located on the starboard side of the transom, just below the rubrail. The engine warranty registration requires the engine serial number(s). Please refer to the engine owner's manual for the location of the serial number(s).

IMPORTANT:

All boat manufacturers are required by the Federal Boat Safety Act of 1971 to notify first time owners in the event any defect is discovered "which creates a substantial risk of personal injury to the public." **It is essential that we have your warranty registration card complete with your name and mailing address in our files so that we can comply with the law if it should become necessary.**

Product Changes

Pursuit is committed to the continuous improvement of our boats. As a result, some of the equipment described in this manual or pictured in the catalog may change or no longer be available. **Pursuit reserves the right to change standard equipment, optional equipment and specifications without notice or obligation.** If you have questions about the equipment on your Pursuit, please contact the Pursuit Customer Relations Department.

Transferring the Warranty

For a transfer fee, S2 Yachts will extend warranty coverage to subsequent owners of Pursuit models for the duration of the original warranty period. Please refer to the Pursuit Limited Warranty Statement for the procedure to transfer the warranty.

To take advantage of this program, notification of the change of ownership, including the new owner's name, address and telephone number together with the appropriate fee, must be sent to Pursuit Fishing Boats, Customer Relations Department, 3901 St. Lucie Boulevard, Ft. Pierce, Florida 34946, within 30 days of the date of resale.

IMPORTANT INFORMATION

S2 Yachts will confirm, in writing, that the transfer of the warranty has taken place. After which, the transferee will be treated as the original purchaser as outlined in the Pursuit Limited Warranty Statement.

Service

All warranty repairs must be performed by an authorized Pursuit dealer. Should a problem develop that is related to faulty workmanship or materials, as stated in the Limited Warranty, you should contact your Pursuit dealer to arrange for the necessary repair. If you are not near your dealer or another authorized Pursuit dealer or the dealer fails to remedy the cause of the problem, then contact the Pursuit Customer Relations Department within 15 days. **It is the boat owner's responsibility to deliver the boat to the dealer for warranty service.**

OWNER'S/OPERATOR'S RESPONSIBILITIES

Registration and Numbering

Federal law requires that all undocumented vessels equipped with propulsion machinery be registered in the state of principal use. A certificate of number will be issued upon registering the boat. These numbers must be displayed on your boat. The owner/operator of a boat must carry a valid certificate of number whenever the boat is in use. When moved to a new state of principal use, the certificate is valid for 60 days.

In order to be valid, the numbers must be installed to the proper specifications. Check with your dealer or State Boating Authority for numbering requirements. The Coast Guard issues the certificate of number in Alaska; all others are issued by the state.

Insurance

In most states the boat owner is legally responsible for damages or injuries he or someone else operating the boat causes. Responsible boaters carry adequate liability and property damage insurance for their boat. You should also protect the boat against physical damage and theft. Some states have laws requiring minimum insurance coverage. Contact your dealer or State Boating Authority for information on the insurance requirements in your boating area.

Reporting Boating Accidents

All boating accidents must be reported by the operator or owner of the boat to the proper marine law enforcement authority for the state in which the accident occurred. Immediate notification is required if a person dies or disappears as a result of a recreational boating accident.

If a person dies or there are injuries requiring more than first aid, a formal report must be filed within 48 hours.

A formal report must be made within 10 days for accidents involving more than \$500.00 damage or the complete loss of a boat.

A Boating Accident Report form is located near the back of this manual to assist you in reporting an accident. If you need additional information regarding accident reporting, please call the Boating Safety Hotline, 800-368-5647.

Education

If you are not an experienced boater, we recommend that the boat operator and other people that normally accompany the operator, enroll in a boating safety course. Organizations such as the U.S. Power Squadrons, United States Coast Guard Auxiliary, State Boating Authorities and the American Red Cross offer excellent boating educational programs. These courses are worthwhile even for experienced boaters to sharpen your skills or bring you up to date on current rules

OWNER'S/OPERATOR'S RESPONSIBILITIES

and regulations. They can also help in providing local navigational information when moving to a new boating area. Contact your dealer, State Boating Authority or the Boating Safety Hotline, 800-368-5647 for further information on boating safety courses.

Required Equipment

U.S. Coast Guard regulations require certain equipment on each boat. The Coast Guard also sets minimum safety standards for vessels and associated equipment. To meet these standards some of the equipment must be Coast Guard approved. "Coast Guard Approved Equipment" has been determined to be in compliance with USCG specifications and regulations relating to performance, construction, or materials. The equipment requirements vary according to the length, type of boat, and the propulsion system. Some of the Coast Guard equipment is described in the Safety Equipment chapter of this manual. For a more detailed description, obtain "Federal Requirements And Safety Tips For Recreational Boats" by contacting the Boating Safety Hotline 800-368-5647 or your local marine dealer or retailer and read the book "Sportfish, Cruisers and Yachts" included with your boat.

Some state and local agencies impose similar equipment requirements on waters that do not fall under Coast Guard jurisdiction. These agencies may also require additional equipment that is not required by the Coast Guard. Your dealer or local boating authority can provide you with additional information for the equipment requirements for your boating area.

TABLE OF CONTENTS

Chapter 1: Propulsion System

| | Page No. |
|-----------------------------------|----------|
| 1.1 General | 1-1 |
| 1.2 Drive Systems Corrosion | 1-2 |
| 1.3 Engine Lubrication | 1-2 |
| 1.4 Engine Cooling System | 1-3 |
| 1.5 Propellers | 1-3 |
| 1.6 Engine Instrumentation | 1-4 |

Chapter 2: Helm Control Systems

| | |
|--|-----|
| 2.1 General | 2-1 |
| 2.2 Engine Throttle and Shift Controls | 2-1 |
| 2.3 Neutral Safety Switch | 2-2 |
| 2.4 Engine Stop Switch | 2-2 |
| 2.5 Engine Power Tilt and Trim..... | 2-3 |
| 2.6 Steering System..... | 2-4 |
| 2.7 Trim Tabs | 2-4 |
| 2.8 Control Systems Maintenance | 2-5 |

Chapter 3: Fuel System

| | |
|-----------------------------------|-----|
| 3.1 General | 3-1 |
| 3.2 Outboard Fuel System | 3-2 |
| 3.3 Fueling Instructions | 3-3 |
| 3.4 Fuel System Maintenance | 3-5 |

TABLE OF CONTENTS

Chapter 4: Electrical System

| | Page No. |
|---|----------|
| 4.1 General | 4-1 |
| 4.2 Batteries | 4-1 |
| 4.3 DC Distribution System | 4-2 |
| 4.4 Switch Panels | 4-2 |
| 4.5 Electrical System Maintenance | 4-4 |

Chapter 5: Freshwater System

| | |
|---|-----|
| 5.1 General | 5-1 |
| 5.2 Freshwater System Operation | 5-1 |
| 5.3 Freshwater System Maintenance | 5-2 |

Chapter 6: Raw Water System

| | |
|--|-----|
| 6.1 General | 6-1 |
| 6.2 High Pressure Washdown | 6-1 |
| 6.3 Livewell | 6-2 |
| 6.4 Raw Water System Maintenance | 6-3 |

Chapter 7: Drainage Systems

| | |
|--|-----|
| 7.1 Cockpit Drainage | 7-1 |
| 7.2 Leaning Post and T-Top Drainage | 7-1 |
| 7.3 Bilge Drainage | 7-2 |
| 7.4 Fishbox and Storage Compartment Drainage | 7-2 |
| 7.5 Sink and Livewell Drains | 7-2 |
| 7.6 Console Cooler Drain | 7-3 |
| 7.7 Maintenance | 7-3 |

TABLE OF CONTENTS

Chapter 8: Exterior Equipment

| | Page No. |
|-----------------------------|----------|
| 8.1 Deck | 8-1 |
| 8.2 Hull | 8-3 |
| 8.3 Cockpit Equipment | 8-3 |
| 8.4 Center Console | 8-4 |

Chapter 9: Interior Equipment

| | |
|------------------------------|-----|
| 9.1 Portable Head | 9-1 |
| 9.2 Marine Head System | 9-2 |

Chapter 10: Safety Equipment

| | |
|--|------|
| 10.1 General | 10-1 |
| 10.2 Engine Alarms | 10-1 |
| 10.3 Neutral Safety Switch | 10-2 |
| 10.4 Engine Stop Switch | 10-2 |
| 10.5 Required Safety Equipment | 10-2 |
| 10.6 First Aid | 10-5 |
| 10.7 Additional Safety Equipment | 10-5 |
| 10.8 Maximum Capacity Rating | 10-6 |

Chapter 11: Operation

| | |
|------------------------------------|------|
| 11.1 General | 11-1 |
| 11.2 Rules of the Road | 11-1 |
| 11.3 Pre-Cruise System Check | 11-3 |
| 11.4 Operating Your Boat | 11-5 |

TABLE OF CONTENTS

Chapter 11: Operation (continued)

| | Page No. |
|---------------------------------|----------|
| 11.5 Grounding and Towing | 11-7 |
| 11.6 Water Skiing | 11-8 |
| 11.7 Fishing | 11-9 |
| 11.8 Trailering Your Boat | 11-9 |

Chapter 12: Routine Maintenance

| | |
|--|------|
| 12.1 Exterior Hull and Deck | 12-1 |
| 12.2 Upholstery, Canvas and Enclosures | 12-4 |
| 12.3 Bilge | 12-6 |
| 12.4 Drainage System | 12-6 |

Chapter 13: Seasonal Maintenance

| | |
|------------------------------|------|
| 13.1 Storage and Layup | 13-1 |
| 13.2 Winterizing | 13-4 |
| 13.3 Recommissioning | 13-6 |

Chapter 14: Schematics

| | |
|--|------|
| Twin Engine 12-Volt Wiring Schematic | 14-1 |
| Single Engine 12-Volt Wiring Schematic | 14-2 |
| Hydraulic Steering System | 14-3 |
| Twin Engine 2 Stroke Fuel System | 14-4 |
| Single Engine 2 Stroke Fuel System | 14-5 |
| Twin Engine 4 Stroke Fuel System | 14-6 |
| Single Engine 4 Stroke Fuel System | 14-7 |
| Freshwater System | 14-8 |
| Raw Water System - Macerator | 14-9 |

TABLE OF CONTENTS

Chapter 14: Schematics (continued)

| | |
|--|-------|
| Holding System - Without Macerator | 14-10 |
| Drainage System | 14-11 |
| | |
| Appendix A: Glossary of Terms | A-1 |
| | |
| Appendix B: Maintenance Log | B-1 |
| | |
| Appendix C: Boating Accident Report | C-1 |

**THIS PAGE WAS LEFT BLANK
INTENTIONALLY**

Chapter 1: PROPULSION SYSTEM

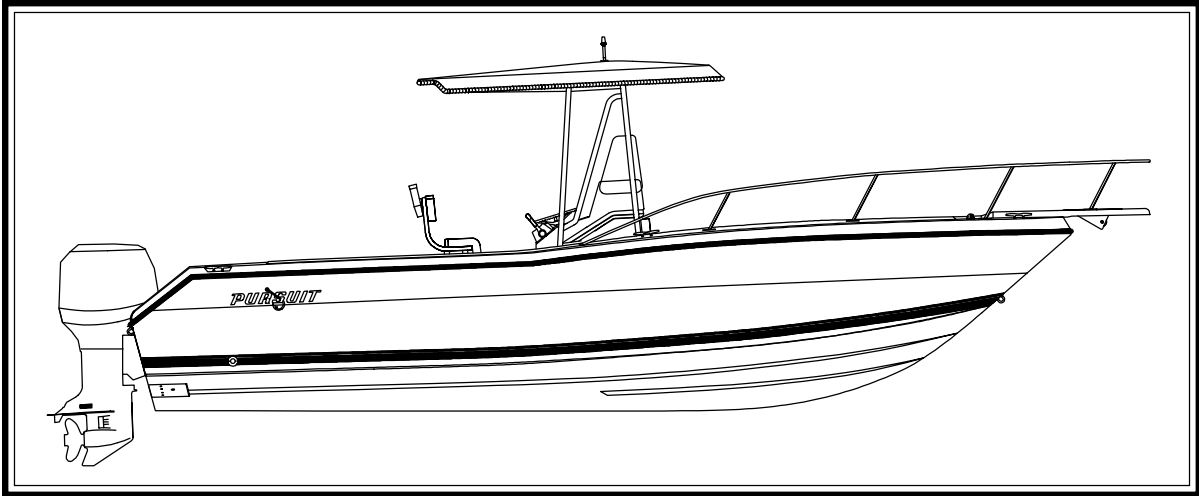

1.1 General

The Pursuit 2470 Center Console is designed to be powered with single or twin 2 cycle or 4 cycle outboard motors. Most 2 cycle outboard motors use an oil injection system. Oil is automatically injected in the engines and mixed at the proper ratio from oil tank(s) located behind access hatches in the stern compartment.

4-cycle outboard engines do not use an oil injection system and are not equipped with remote oil tanks. They have an oil sump in the crankcase that must be kept full of the type of oil recommended by the engine manufacturer. The oil must be checked before each use and changed regularly.

Each manufacturer of the various outboard motors provides an owner's information manual with its product. It is important that you read the manual very carefully and become familiar with the proper care and operation of the engine and drive system. A warranty registration card has been furnished with each new engine and can be located in the engine owner's manual. All information requested on this card should be filled out completely by the purchaser and then returned to the respective engine manufacturer as soon as possible.



DO NOT ATTEMPT TO SERVICE ANY ENGINE OR DRIVE COMPONENT WITHOUT BEING TOTALLY FAMILIAR WITH THE SAFE AND PROPER SERVICE PROCEDURES. CERTAIN MOVING PARTS ARE EXPOSED AND CAN BE DANGEROUS TO SOMEONE UNFAMILIAR WITH THE OPERATION AND FUNCTION OF THE EQUIPMENT.

1.2 Drive Systems Corrosion

Each outboard motor is a complete drive system with the gear case being just forward of the propeller and connected to the power head with a vertical drive shaft. Other than the routine maintenance outlined in the engine owner's manual, there is little to be concerned with unless the boat is to be kept in saltwater for extended periods of time. Then, the main concerns are marine growth and galvanic corrosion.

Marine growth occurs when components are left in the water for extended periods and can cause poor performance or permanent damage to the exposed components. The type of growth and how quickly it occurs is relative to the water conditions in your boating area. Water temperature, pollution, current, etc. can have an effect on marine growth.

Galvanic corrosion is the corrosion process occurring when different metals are submerged in an electrolyte. Sea water is an electrolyte and submerged engine components must be properly protected. Outboard motors are equipped with sacrificial anodes to prevent galvanic corrosion problems. The anodes must be monitored and replaced as necessary. For locations and maintenance, please refer to the engine owner's manual.

When leaving the boat in the water, tilt the motor as high as possible. This will decrease the risk of marine growth around the cooling inlets, propeller and exhaust ports and damage from galvanic corrosion.



DO NOT PAINT THE OUTBOARD MOTORS WITH ANTIFOULING PAINTS DESIGNED FOR BOAT HULLS. MANY OF THESE PAINTS CAN CAUSE SEVERE DAMAGE TO THE ENGINES. CONTACT YOUR PURSUIT DEALER OR ENGINE MANUFACTURER FOR INFORMATION ON THE PROPER PAINTING PROCEDURES.

1.3 Engine Lubrication

2-cycle outboard motors are lubricated by a variable ratio oil injection system. The oil tanks are mounted below the stern bait station near the transom. Always monitor the oil level before each cruise by checking the gauge in the helm or visually checking the oil level using the reference marks on the tanks. When additional oil is needed, use only the type of oil specified by the engine manufacturer. Refer to the engine owner's manual for oil specifications and additional information on the oil injection system.

Note: Always monitor the oil level in the tanks and only use the type of oil specified by the engine manufacturer.

4-cycle outboard engines have an oil sump in the crankcase that must be kept full of the type and grade of oil recommended by the engine manufacturer. It is normal for 4-cycle engines to consume a small amount of oil. Therefore, the oil must be checked before each use and changed at regular intervals as instructed by the engine owner's manual. As with 2-cycle engines, use only the type of oil specified by the engine manufacturer.

1.4 Engine Cooling System

Outboard engines are raw water (sea water) cooled. Water is pumped through the water inlets, circulated through the engine block, and relinquished with the exhaust gases through the propeller hub. The water pump uses a small impeller made of synthetic rubber. The impeller and water pump cannot run dry for more than a few seconds. In most outboard motors, some cooling water is diverted through small ports below the engine cowling. This allows the operator to visually check the operation of the cooling system. When the engine is started, always check for a steady stream of water coming out of those ports.



NEVER RUN AN OUTBOARD MOTOR WITHOUT WATER FLOWING TO THE WATER PUMP. SERIOUS DAMAGE TO THE WATER PUMP IMPELLER OR ENGINE COULD RESULT.

Note: If the boat is used in salt or badly polluted water, the engine(s) should be flushed after each use. Refer to the engine owner's manual for the proper engine flushing procedure.

1.5 Propellers

The propellers convert the engine's power into thrust. They come in a variety of styles, diameters and pitches. The one that will best suit the needs of your Pursuit will depend somewhat on your application and expected average load. Propeller sizes are identified by two numbers stamped on the prop in sequence. The 1st number in the sequence (example 14 x 21) is the diameter of the propeller and the 2nd number is the pitch. Pitch is the theoretical distance traveled by the propeller in each revolution. Always repair or replace a propeller immediately if it has been damaged. A damaged and therefore out of balance propeller can cause vibration that can be felt in the boat and could damage the engine gear assembly. Refer to the engine owner's manual for information on propeller removal and installation.



RUNNING AGROUND OR STRIKING AN UNDERWATER OBSTRUCTION CAN RESULT IN SERIOUS INJURY AND DAMAGE TO THE MOTOR OR BOAT. IF YOUR BOAT RUNS AGROUND, EVALUATE THE DAMAGE THEN PROCEED AT LOW SPEED TO THE NEAREST SERVICE FACILITY AND HAVE AN IMMEDIATE INSPECTION MADE BEFORE FURTHER USE OF THE CRAFT. A DAMAGED BOAT CAN TAKE ON WATER. KEEP ALL LIFE SAVING DEVICES CLOSE AT HAND WHILE DRIVING TO A DOCK AREA. IF THE BOAT CANNOT BE IMMEDIATELY REMOVED FROM THE WATER, THOROUGHLY INSPECT THE BILGE AREA FOR LEAKS SO THAT THE BOAT DOES NOT SINK WHILE MOORED.

1.6 Engine Instrumentation

The helm station is equipped with a set of engine instruments and/or alarms. These instruments allow the pilot to monitor the engine's operational conditions. Close observation of these instruments allows the pilot to operate the engine(s) at the most efficient level and could save the engine(s) from serious costly damage. The instrumentation is unique to the type of outboard motors installed on your Pursuit. Some or all of the following gauges may be present.

Tachometer

The tachometer displays the speed of the engine(s) in revolutions per minute (RPM) This speed is not the boat speed nor necessarily the speed of the propeller. The tachometer may not register zero with the key in the "OFF" position.



NEVER EXCEED THE MAXIMUM RECOMMENDED OPERATION RPM OF THE ENGINE. MAINTAINING MAXIMUM, OR CLOSE TO MAXIMUM RPM FOR EXTENDED PERIODS CAN REDUCE THE LIFE OF THE ENGINE.

Speedometer

The speedometer indicates the speed of the boat in miles per hour.

Temperature Warning

The temperature warning indicates the temperature of the engine. A sudden increase in the temperature could indicate an obstructed water inlet or an impeller failure.



CONTINUED OPERATION OF AN OVERHEATED ENGINE CAN RESULT IN ENGINE SEIZURE. IF AN UNUSUALLY HIGH TEMPERATURE READING OCCURS, SHUT THE ENGINE OFF IMMEDIATELY. THEN INVESTIGATE AND CORRECT THE PROBLEM.

Fuel Gauge

The fuel gauge indicates the amount of fuel in the fuel tank.

Voltmeter

The voltmeter displays the voltage for the battery and the charging system. The normal voltage is 11 to 12-volts with the engine off, and 13 to 14.5 volts with the engine(s) running.

Hour Meter

The hour meter keeps a record of the operating time for the engine.

Engine Alarms

Most outboards are equipped with an audible alarm system mounted in the helm area that monitors selected critical engine systems. The alarm will sound if one of these systems begins to fail. Refer to the engine owner's manual for information on the alarms installed with your engines.



IF THE ENGINE ALARM SOUNDS, IMMEDIATELY SHUT OFF THE ENGINE UNTIL THE PROBLEM IS FOUND AND CORRECTED.

Tilt/Trim Gauge

The tilt/trim gauge monitors the position of the engine. The upper range of the gauge indicates the tilt, which is used for trailering and shallow water operation. The lower range indicates the trim position. This is the range used to adjust the hull angle while operating your boat on plane. Please refer the engine owner's manual for more information on the operation of the outboard power tilt and trim.

Fuel Management Gauge

Fuel management systems are optional equipment with some outboard engines. On Yamaha® engines, the fuel management gauge is a multifunction gauge used to monitor the gallons per hour, miles per gallon, and engine synchronization. If you have a fuel management system installed on your boat, please refer to the engine or fuel management manual for information on that system.

Compass

The compass is on top of the helm. To adjust the compass for your area, read the instructions on "Compass Compensation" given to you in the literature packet. The compass cannot be adjusted accurately at the factory as it must be compensated for the influence of the electrical equipment and electronics unique to your boat. Therefore, the compass should be adjusted by a professional after the electronics and additional electrical accessories are installed and before operating the boat.

Instrument Maintenance

Electrical protection for instruments and ignition circuitry is provided by a set of circuit breakers located near the main battery switch. The ignition switches should be sprayed periodically with a contact cleaner/lubricant. The ignition switches and all instruments, controls, etc. should be protected from the weather when not in use. Excessive exposure can lead to gauge and ignition switch difficulties.

Chapter 2:

HELM CONTROL SYSTEMS

2.1 General

The helm controls consist of three systems: the engine throttle and shift controls, the steering system, and the trim tab control switches. These systems provide the operator with the ability to control the direction and attitude of the boat from the helm station.

Each manufacturer of the control components provides an owner's manual with its product. It is important that you read the manuals and become familiar with the proper care and operation of the control systems.

2.2 Engine Throttle and Shift Controls

The shift and throttle controls on your boat may vary depending on the engines used. The following control description is typical of most outboard remote controls. Refer to the engine or control manual for specific information on the controls installed on your Pursuit.

The engine throttle and shift control system consists of three major components: the control handles, the throttle cable, and the shift cable. The cables are the push-pull type. Two cables are required. One connects the remote throttle control to the carburetor or fuel injection system and the other connects the remote shift control to the engine shift rod linkage.

The helm on your Pursuit is designed for a binnacle style control with a single lever for each engine that operates as a gear shift and a throttle. General operation will include a position for neutral (straight up and down), a forward position (the 1st detent forward of neutral), and a reverse position (the 1st detent aft of neutral). Advancing the control lever beyond the shift range advances the throttle in forward or reverse. Each control is equipped with a means of permitting the engine to be operated at a higher than idle RPM while in neutral for cold starting and warm-up purposes. See your engine owner's manual for details of this operation.

The handles of dual lever controls may not always align with each other at all rpm settings due to variations in control cable routing, cable length and adjustments at the engine. Usually the alignment of the handles can be optimized at a chosen rpm, but may vary at other settings.

2.3 Neutral Safety Switch

Every control system has a neutral safety switch incorporated into it. This device prohibits the engine from being started while the shift lever is in any position other than the neutral position. If the engine will not start, slight movement of the shift lever may be necessary to locate the neutral position and disengage the safety cutout switch. Control or cable adjustments may be required to correct this condition should it persist. See your Pursuit dealer for necessary control and cable adjustments.

The neutral safety switch should be tested periodically to ensure that it is operating properly. To test the neutral safety switch, make sure the engines are tilted down and move the shift levers to the forward position. ***Make sure the control levers are not advanced past the idle position.*** Turn the ignition key to the start position just long enough to briefly engage the starter for the engine. ***Do not hold the key in the start position long enough to start the engine.*** The starter should not engage for either engine. Repeat this test with the shift levers in reverse and the engine throttles at idle. Again, the starter should not engage for either engine. If the starter for either engine engages with the shift controls in any position other than the neutral position, then the neutral safety switch is not functioning properly and you should contact your dealer and have the neutral safety switch repaired before using your boat. If an engine starts in gear during this test, immediately move the control levers to the neutral position. Turn the engines off and have the problem corrected by a qualified marine mechanic before using the boat.



IN SOME SITUATIONS, IT MAY BE POSSIBLE TO ACCIDENTALLY START AN ENGINE IN GEAR WITH THE THROTTLE ABOVE IDLE IF THE NEUTRAL SAFETY SWITCH IS NOT OPERATING PROPERLY. THIS WOULD CAUSE THE BOAT TO ACCELERATE UNEXPECTEDLY IN FORWARD OR REVERSE AND COULD RESULT IN LOSS OF CONTROL, DAMAGE TO THE BOAT, OR INJURY TO PASSENGERS. ALWAYS TEST THE NEUTRAL SAFETY SWITCH PERIODICALLY AND CORRECT ANY PROBLEMS BEFORE USING THE BOAT.

2.4 Engine Stop Switch

All Pursuit boats rigged with outboard motors are equipped with an engine stop switch and lanyard. When the lanyard is pulled it will engage the switch and shut off the engine(s). We strongly recommend that the lanyard be attached to the driver whenever the engines are running. If the engine(s) will not start, it could be because the lanyard is not properly inserted into the stop switch. Always make sure the lanyard is properly attached to the engine stop switch before attempting to start the engine(s).

Please refer to the engine owner's manual for additional information on the engine stop switch.



Engine Stop Switch

2.5 Engine Power Tilt and Trim

All outboard engines have a tilt and trim feature. The tilt and trim switches are usually built into the engine shift and throttle controls and allows the operator to control the position of the outboards from the helm. Moving the outboards closer to the boat transom is called trimming “in” or “down.” Moving the outboards further away from the boat transom is called trimming “out” or “up.” In most cases, the boat will run best with the outboards adjusted so the hull will run at a 3 to 5 degree angle to the water.

The term “trim” generally refers to the adjustment of the outboards within the first 20° range of travel. This is the range used while operating your boat on plane. The term “tilt” is generally used when referring to adjusting the outboards further up for shallow water operation or trailering. For information on the proper use and maintenance of the power tilt and trim, please refer to the engine owner’s manual.



THE ENGINE HOSES AND CABLES OR THE TRANSOM GEL COAT CAN BE DAMAGED BY TILTING THE ENGINES TO THE FULL UP POSITION WITH THE ENGINES TURNED TO THE WRONG POSITION. ALL TWIN ENGINE AND MOST SINGLE ENGINE BOATS REQUIRE THE STEERING WHEEL TO BE TURNED COMPLETELY TO STARBOARD BEFORE TILTING THE ENGINES TO THE FULL UP POSITION. YOU SHOULD MONITOR THE ENGINES AS THEY TILT TO DETERMINE BEST FULL TILT ENGINE POSITION FOR YOUR BOAT.



SOME AUTOPILOTS HAVE ENGINE POSITION SENSORS THAT ARE MOUNTED TO THE HYDRAULIC STEERING CYLINDER. WITH THESE AUTOPILOTS, THE ENGINE POSITION SENSOR BRACKET COULD HIT THE TRANSOM WHEN THE ENGINES ARE TILTED TO THE FULL UP POSITION AND CAUSE DAMAGE TO THE ENGINE RIGGING, THE AUTOPILOT OR THE TRANSOM. IF YOU HAVE AN AUTOPILOT INSTALLED ON YOUR BOAT, YOU SHOULD MONITOR THE LOCATION OF THE ENGINE CABLES AND AUTOPILOT BRACKETS AS THE ENGINES ARE TILTED TO DETERMINE THE BEST ENGINE POSITION AND MAXIMUM ENGINE TILT FOR YOUR APPLICATION.

2.6 Steering System

The steering system is hydraulic and made of two main components: the helm assembly and the hydraulic cylinder. The helm unit acts as both a fluid reservoir and pump. Turning of the helm, or steering wheel, pumps the fluid in the hydraulic hoses and activates the hydraulic cylinder causing the motors to turn. A slight clicking sound may be heard as the wheel is turned. This sound is the opening and closing of valves in the helm unit and is normal. Refer to the manufacturer owner's manual for specific information on the steering system.

2.7 Trim Tabs

Pursuit uses a dual toggle switch to control the trim tabs. The switch is labeled and controls bow up and down movements. It also controls starboard and port up and down movements. Bow up and bow down will control the hull planing attitude while port and starboard up and down provides control for the hull listing.



Trim Tab Switch

Before leaving the dock, make sure that the tabs are in the full “UP” position by holding the control in the bow up position for ten (10) seconds.

Always establish the intended heading and cruise speed before attempting to adjust the hull attitude with the trim tabs. After stabilizing speed and direction, move the trim tabs to achieve a level side to side running attitude, being careful not to over trim. After depressing a trim tab switch, always wait a few seconds for the change in trim plane to take effect. **Avoid depressing the switch while awaiting the trim plane reaction.** By the time the effect is noticeable, the trim plane will have moved too far and thus the boat will be in an overcompensated position.

When running at a speed that will result in the boat falling off plane, lowering the tabs slightly, bow down, will improve the running angle and operating efficiency. Too much bow down can reduce operating efficiency and cause substantial steering and handling difficulties.

Be extremely careful when operating in a following sea. The effect of trim tabs is amplified under such conditions. Steering and handling difficulties can result from improper trim tab usage, particularly in a following sea. Always raise the tabs to the full bow up position in these conditions.

When running at high speeds be sure that the tabs are in the full “UP” position. Only enough trim plane action should be used to compensate for any listing. Trim tabs are extremely sensitive at high speeds. Adjust for this and be prepared to slow down if difficulties arise.

When running into a chop, a slight bow down attitude will improve the ride. Be careful not to over trim. Handling difficulties may result.

2.8 Control Systems Maintenance

Control Maintenance

Periodic inspection of the control systems and all connections should be made. Signs of rust, corrosion, wear, or other deterioration should immediately be serviced. Generally, periodic lubrication of all moving parts and connections with a light waterproof grease is in order.

Lubrication should be performed as often as necessary to keep the system operating smoothly.

Control system adjustments may become necessary. If adjustment becomes necessary, see your Pursuit dealer.



DO NOT ATTEMPT CONTROL SYSTEM ADJUSTMENTS UNLESS YOU ARE FAMILIAR WITH CONTROL SYSTEM SERVICING PROCEDURES. MISADJUSTMENT CAN CAUSE LOSS OF CONTROL AND SEVERE ENGINE OR LOWER UNIT DAMAGE.

Steering System Maintenance

A periodic inspection of all steering cables, hoses, linkage and helm assemblies should be made. Signs of corrosion, cracking, loosening of fastenings, excessive wear, or deterioration should be immediately corrected. Generally, periodic lubrication of all moving parts and connections with a light waterproof grease is in order. Failure to do so could lead to steering system failure that would result in loss of control.

When new, or after repairs, hydraulic steering systems may need to have all air purged from the system. Review the information provided by the steering manufacturer for proper specifications and details on system service and maintenance.

Trim Tab Maintenance

Marine growth can interfere with the proper operation of the trim tab planes and actuators. To reduce problems due to marine growth, always return the trim tabs to the full “UP” position after operating the boat and periodically inspect and clean marine growth from the actuators and planes.

The trim tab fluid should be checked often. Keep the fluid level between the marks on the trim tab pump reservoir.

If your Pursuit will be left in saltwater for extended periods, it may be necessary to install zinc anodes on the trim tab planes to prevent galvanic corrosion. Refer to the trim tab owner’s manual for additional maintenance information and fluid specifications.

**THIS PAGE WAS LEFT BLANK
INTENTIONALLY**

Chapter 3:

FUEL SYSTEM

3.1 General

The gasoline fuel system used in Pursuit boats is designed to meet or exceed the requirements of the U.S. Coast Guard, the Boating Industry Association, and The American Boat and Yacht Council in effect at the time of manufacture.

All gasoline fuel systems have been factory inspected and pressure tested in accordance with regulations in effect at the time of manufacture. This inspection assures that the system is air tight, leak proof and safe. It is the responsibility of the purchaser to maintain it in that condition. Make frequent inspections to assure that no deterioration or loosening of connections is resulting from vibration.



DO NOT LET THE ODOR OF GASOLINE GO UNCHECKED. ANY ODOR OF GASOLINE MUST BE IMMEDIATELY INVESTIGATED AND STEPS TAKEN TO PROTECT THE BOAT AND ITS OCCUPANTS UNTIL THE PROBLEM IS CORRECTED. IF THE ODOR OF GASOLINE IS NOTED, SHUT OFF ALL ENGINES AND ELECTRICAL EQUIPMENT TO INVESTIGATE AND CORRECT THE SITUATION IMMEDIATELY. HAVE ALL PASSENGERS PUT ON PERSONAL FLOTATION DEVICES AND KEEP THE FIRE EXTINGUISHER READY UNTIL THE SITUATION IS RESOLVED.

Fuel Withdrawal Tubes

The fuel withdrawal tubes are positioned in the fuel tank to achieve optimum fuel usage, fuel line routing, etc. At certain speeds and hull trim angles, the fuel supply at the withdrawal tank location can increase or decrease accordingly. Be extremely careful when attempting to operate the boat when low on fuel. Though some fuel may be in the tank, the relative trim angle of the boat may cause the fuel to flow away from the withdrawal.

Fuel Gauge

This indicates the amount of fuel in the tank. Due to the mechanical nature of the fuel sender, variations in readings during various speeds of operation may occur. This system is merely a relative indication of the available fuel supply and not a calibrated instrument.

Fuel Fill

The fuel fill deck plate is located on each gunnel, and is marked "GAS." The fuel fill is opened by turning it counter clockwise with a special key. After fueling, install the fuel cap and tighten with the key. Be sure to use the proper type and grade fuel. Refer to the engine owner's manual for additional information.

Note: Do not overtighten the fuel cap. If the cap is overtightened, the O-ring seal could be damaged allowing water to contaminate the fuel system.



DO NOT CONFUSE FUEL FILL DECK PLATES WITH THE WATER OR WASTE FILL DECK PLATES. THESE PLATES ARE ALSO LABELED ACCORDINGLY. IF GASOLINE IS ACCIDENTALLY PUMPED INTO THE WATER OR WASTE TANK, DO NOT ATTEMPT TO PUMP IT OUT YOURSELF. WATER AND WASTE PUMPS ARE NOT DESIGNED TO PUMP FUEL AND A FIRE OR EXPLOSION COULD RESULT. CONTACT YOUR DEALER OR THE PURSUIT CUSTOMER RELATIONS DEPARTMENT FOR ASSISTANCE IN HAVING THE FUEL PROFESSIONALLY REMOVED.

Fuel Vent

The fuel vent is located on the side of the hull. While the tank is being filled, the air displaced by the fuel escapes through the vent.

After fueling, replace the fill cap and wash the areas around the fuel fill deck plate and below the fuel vent. Residual fuel left on the deck and hull sides can be dangerous and will yellow the fiberglass or damage the striping.

3.2 Outboard Fuel System

The fuel system on the Pursuit 2470 Center Console has one fuel tank. The fuel tank is mounted in the center of the bilge and has one or two withdrawal lines equipped with anti-siphon valves where the fuel lines attach to the fuel tank. This valve prevents gasoline from siphoning out of the fuel tank should a line rupture.



Fuel Filter



DO NOT REMOVE THE ANTI-SIPHON VALVES FROM THE SYSTEM. SHOULD AN ANTI-SIPHON VALVE BECOME CLOGGED, CLEAN AND REINSTALL OR REPLACE. IF A FUEL LINE SHOULD LEAK, ANTI-SIPHON VALVES PREVENT A SUBSTANTIAL AMOUNT OF FUEL FROM FLOWING INTO THE BILGE. ANTI-SIPHON VALVES ARE REQUIRED, BY THE U.S. COAST GUARD, TO BE INSTALLED IN ALL BOATS EQUIPPED WITH GASOLINE ENGINES.

Twin Engine Fuel System (Optional)

Twin engine 2470 Center Consoles use both fuel withdrawal lines, one for each engine. A fuel filter for each engine is installed in the transom area of the boat. The filters are the water separator type and have a sediment bowl that should be checked for water frequently to assure an adequate supply of clean, dry fuel to the engines. It is recommended that the filters be inspected periodically and the element changed as needed.

Single Engine Fuel System (Optional)

Single engine 2470 Center Consoles use one fuel withdrawal line. A fuel filter for the engine is installed in the transom area of the boat. It is the same filter as those used on the twin engine boats.

3.3 Fueling Instructions



FUEL IS VERY FLAMMABLE. BE CAREFUL WHEN FILLING THE FUEL TANK. NO SMOKING. NEVER FILL THE TANK WHILE THE ENGINE IS RUNNING. FILL THE FUEL TANK IN AN OPEN AREA. DO NOT FILL THE TANK NEAR OPEN FLAMES.



TO PREVENT DAMAGE TO THE FUEL SYSTEM, USE ONLY A GOOD GRADE OF GASOLINE FOR GASOLINE ENGINES. DO NOT USE A FUEL THAT CONTAINS HARSH ADDITIVES OR IS AN ALCOHOL BLEND. ANY DAMAGE DONE TO THE FUEL SYSTEM THAT IS THE RESULT OF USE OF AN ALCOHOL BLEND, IS NOT COVERED BY THE PURSUIT WARRANTY. REFER TO THE ENGINE MANUFACTURER OWNER'S MANUAL REGARDING FUEL REQUIREMENTS FOR YOUR ENGINE(S).

To fill the fuel tank at a marina, follow this procedure:

1. Make sure all switches are in the "OFF" position.
2. Make sure the boat is securely moored.
3. Make sure all passengers leave the boat.
4. Estimate how much fuel is needed.

Note: When the fuel tank is full, fuel will come out through the fuel vent. The fuel vent is located on the port side of the boat.

5. A special key to open the fuel cap is supplied.
6. Turn the key counterclockwise to open the cap.

7. Remove the cap.
8. Put the nozzle in the fuel opening.



STATIC ELECTRICITY CAN BE GENERATED WHILE FUELING AND CAN CAUSE A FIRE OR EXPLOSION. TO PREVENT STATIC SPARKS WHEN FILLING THE TANK, MAKE SURE THE NOZZLE IS IN CONTACT WITH THE FUEL OPENING.



SPILLED FUEL CAN CAUSE A FIRE OR AN EXPLOSION. MAKE SURE YOU DO NOT SPILL ANY FUEL. IF A SMALL AMOUNT OF FUEL IS SPILLED ON THE FIBERGLASS, USE A CLOTH TO REMOVE THE FUEL AND PROPERLY DISPOSE OF THE CONTAMINATED CLOTH. IF FUEL IS SPILLED ON THE WATER, EXERCISE EXTREME CAUTION. FUEL FLOATS ON THE SURFACE OF THE WATER AND CAN IGNITE. IF FUEL IS SPILLED INTO THE WATER, IMMEDIATELY EVACUATE THE AREA AND NOTIFY THE MARINA AND THE PROPER OFFICIALS.

9. Fill the tank slightly less than the rated capacity to avoid spilling fuel out of the vent and fuel fill and to allow for expansion.
10. Remove the nozzle.
11. Install the fuel cap. Be careful not to overtighten the cap.
12. Check the fuel compartment and below the deck for fuel odors. If you smell fuel, do not start the engine.



TO REDUCE THE RISK OF A FIRE AND/OR EXPLOSION, DO NOT START THE ENGINE(S) WHEN FUEL FUMES ARE PRESENT. FUEL FUMES ARE DANGEROUS AND HARMFUL TO YOUR HEALTH.



MAKE SURE ALL GASOLINE ODORS ARE INVESTIGATED IMMEDIATELY.

3.4 Fuel System Maintenance

Periodically inspect all primer bulbs, connections, clamps and hoses for leakage and damage or deterioration. Replace as necessary. Spray the valves, tank fuel gauge sender and ground connections with a metal protector.

Frequently inspect and lubricate the fuel fill cap O-ring seal with petroleum jelly or silicone grease. The O-ring seal prevents water from entering the fuel system through the fuel fill cap. It should be immediately replaced if there is any sign of damage or deterioration.

Periodically, remove the fuel vent and clean corrosion and salt buildup from the vent screens. The screens will prevent insects and other foreign matter from contaminating the fuel and fuel system. The fuel vent should be replaced if the vents or screens are damaged or badly corroded. Fuel vent screens that are clogged will prevent the fuel tank from venting properly and make filling the tank difficult or cause fuel supply problems to the engines.

Be sure the screens are secure and that the fuel tank vent hose is properly routed and attached when the vent is reinstalled or replaced. The fuel tank vent hose must be looped above the vent, secured to the hull near the vent and securely attached to the vent hose fitting with two hose clamps.

Contaminated fuel may cause serious damage to your engines. The fuel filters must be checked for water and other contamination frequently. The filter elements must be changed at least once a season or more frequently depending on the type of engine and the quality of the fuel. The fuel filters and primer bulbs are located in the stern and are accessed by opening the hatch near the transom door.

The age of gasoline can affect engine performance. Chemical changes occur as the gasoline ages that can cause deposits and varnish in the fuel system as well as reduce the octane rating of the fuel. Severely degraded fuel can damage the engine and boat fuel tank and lines. Therefore, if your boat is not being run enough to require at least one full tank of fresh fuel a month, a fuel stabilizer should be added to the gasoline to protect the fuel from degradation. Your dealer or the engine manufacturer can provide additional information on fuel degradation and fuel stabilizers recommended for your engine.

Avoid using fuels with alcohol additives. Gasoline that is an alcohol blend will absorb moisture from the air which can reach such concentrations that "phase separation" can occur whereby the water and alcohol mixture becomes heavy enough to settle out of the gasoline to the bottom of the tank. Since the fuel pick up tube is very near the bottom of the tank, phase separation can cause the engine to run very poorly or not at all. This condition is more severe with methyl alcohol and will worsen as the alcohol content increases. Water or a jelly like substance in the fuel filters is an indication of phase separation from the use of alcohol blended fuels.



DO NOT DRAIN ANY FUEL INTO THE BILGE. THIS COULD LEAD TO A FIRE OR EXPLOSION.



AFTER THE FILTER ELEMENT HAS BEEN CHANGED, PRIME THE FUEL SYSTEM AND CHECK ALL FITTINGS FOR LEAKS BEFORE AND AFTER STARTING THE ENGINE.

Chapter 4: ELECTRICAL SYSTEM

4.1 General

Your Pursuit is equipped with a 12-volt D.C. electrical system that draws current from onboard batteries.

The 12-volt system is a fairly standard system. The batteries are charged by the engine(s). All 12-volt power is distributed to the 12-volt accessories through individual circuit breakers located in the 12-volt switch panels. A main circuit breaker located near the battery switch protects the system from an overload. Another circuit breaker near the switch protects the circuit for the automatic float switch for the bilge pump. Most 12-volt accessories are operated directly by switches in the helm and accessory switch panels.

The 12-volt batteries in your boat are the lead-acid type. They will require maintenance similar to those found in automobiles. The batteries are located in the stern bilge. The starboard battery is located near the battery switches and the port battery is below the removable stern tackle locker. To access the port battery, remove the top tackle locker drawer and remove the quick release pin, then slide the locker out of the frame.

There are electrical schematics included in this manual to aid in following an individual circuit of the boat.



PROPER FUSE OR BREAKER PROTECTION MUST BE PROVIDED FOR ALL 12-VOLT EQUIPMENT ADDED. DO NOT OVERLOAD THE ACCESSORY CIRCUIT BREAKERS OR OTHER CIRCUITRY THROUGH ADDITIONAL 12-VOLT EQUIPMENT.

4.2 Batteries

Pursuit electrical systems are designed to use lead-acid type batteries. Your boat has provision for two batteries. These batteries should be of the size and capacity recommended by the manufacturer of your engine. See the engine owner's manual. These specifications should be considered to be the minimum size battery required. Consider increasing the capacity of the battery if you will be trolling, drift fishing or have extensive electronics on board. Larger batteries will give you additional capacity to operate the livewell, washdown, and electronics at low speed when the charging system output of the engines is minimal.

4.3 DC Distribution System

The battery switches are a part of an integrated DC power distribution system that contain several components. The following are descriptions of the components:

| | |
|-------------------------------|---|
| Battery Master Switch (2) | These switches feed the engine(s) and DC circuits. |
| Engine Parallel Switch | Connects the two batteries together for engine starting or charging of both batteries. |
| Voltage Sensitive Relay (VSR) | Used on single engine applications only. The VSR allows both batteries to be charged by one engine and prevents both batteries from being discharged. |
| 24-Hour Essential Circuits | Used for protection of circuits that are not switched off by battery master switches. |
| Medium Duty Circuit Breaker | Used to protect high amperage circuits and panel feeds. |
| Heavy Duty Circuit Breaker | Used to protect the windlass circuit. |
| Heavy Duty Distribution Stud | One or more of these may be used to distribute negative DC Power. |
| Heavy Duty Buss | Contains multiple distribution studs to distribute negative DC power. |
| Blank Module | Acts as a filler to complete the modular design. |

4.4 Switch Panels

The main accessory switch panel is located at the helm. The circuit breakers that protect the accessories are located directly under the switches.

The following is a description of the accessories controlled by the main accessory switch panel:

Horn

Activates the boat horn.

Bilge Pump

The bilge pump is installed in the rear center of the bilge. The pump moves water out through the thru-hull fittings in the transom. To start the pump manually, put the switch in the “ON” position.

Note: The bilge pump will start automatically when there is sufficient water in the bilge to activate the float switch. The float switch is protected by a circuit breaker located near the battery selector switch and is always supplied current when the batteries are connected.

Anchor-Nav Lights

The switch is a three-position switch. The middle position is "OFF." Moving the switch in one direction will activate the navigation lights. Moving the switch in the opposite direction activates the anchor light.

Courtesy Lights

Activates the lights that illuminate the cockpit area.

Panel Lights

Activates the engine gauge and compass lights.

Accessory Switches

These switches are supplied to activate additional equipment that may have been installed by Pursuit or your Pursuit dealer. If no accessories are activated by these switches, they remain wired in the panel in reserve.

12-Volt Receptacle

Provides electrical current for portable 12-volt equipment.

Additional Switch Panels

Additional switch panels may be located in various locations in the cockpit and helm area of the boat. Most of these panels are equipped with one switch and one circuit breaker. The following is a description of additional panels that may be on your Pursuit and the accessories they control:

Baitwell Switch

This switch activates the baitwell circulating pump that supplies water to the baitwell.

Washdown Pump

This switch activates the raw water washdown pump. A pressure switch automatically controls the water pump when the system is activated and properly primed.

Macerator (Optional)

Supplies electrical current to the switch, that controls the macerator overboard discharge pump for the holding tank. This switch is located below the battery selector switch or near the Y-valve in the stern of the boat.

Note: Please refer to chapter 6 for more information on the baitwell and washdown systems.

Trim Tab Switch

Located in the helm. This switch controls the trim tab planes located on the transom of the boat. It is protected by a breaker located behind the helm at the back of the accessory switch. Please refer to chapter 2 for detailed information on the operation of the trim tab controls.

Windlass Switch (Optional)

Located in the helm. This switch controls the optional windlass which is mounted to the deck directly above the rope locker. It is protected by a circuit breaker of the type and rating recommended by the windlass manufacturer.

Windlass Breaker

The windlass breaker is located on the helm next to the windlass switch. Raise the lever on the breaker to activate the windlass control switch and push the red button to return the breaker to “OFF” whenever the windlass is not in use. This breaker is provided to protect the windlass electrical circuit and reduce the possibility of accidentally activating the windlass.

4.5 Electrical System Maintenance

D.C. Electrical System Maintenance

At least once a year, spray all exposed electrical components behind the helm and in the plugs, with a protector. Exterior light fixture bulbs should be removed and the metal contact areas coated with a non-water soluble lubricant like petroleum jelly. The sockets should be sprayed with a protector. Care must be taken not to get any oil or petroleum jelly on the glass portion of the bulbs as this will cause the bulb to overheat and burn out.



WHEN REPLACING LIGHT BULBS IN MARINE LIGHT FIXTURES, ALWAYS USE A BULB WITH THE SAME RATING AS THE ORIGINAL. USING A DIFFERENT BULB COULD CAUSE THE FIXTURE TO OVERHEAT AND MELT OR SHORT CIRCUIT.

Inspect all wiring for proper support, sound insulation, and tight terminals, paying particular attention to portable appliance cords and plugs.

Check all below deck wiring to be sure it is properly supported, that the insulation is sound, and that there are no loose or corroded terminals. Corroded terminals should be thoroughly cleaned with sandpaper, or replaced, tightened securely and sprayed with a metal and electrical protector. Inspect all engine wiring.

Check the electrolyte level in the batteries regularly and add distilled water as necessary. If the batteries are frequently charged by an automatic battery charger, the electrolyte level will have to be checked more often. Keep the battery tops clean and dry. Dirt and water can conduct electricity from one post to the other causing the battery to discharge. The battery posts should be kept free of corrosion. Remove the cables and clean the posts and cable clamps with a battery post cleaner or sandpaper as required. Coating the battery posts and cable clamps with petroleum jelly will protect them and reduce corrosion. Battery cables, both hot and ground, must be replaced when they show signs of corrosion or fraying. Deteriorated cables cause a considerable voltage loss when high currents are drawn, as for starting the engine.



NEVER USE AN OPEN FLAME IN THE BATTERY STORAGE AREA. AVOID STRIKING SPARKS NEAR THE BATTERY. A BATTERY CAN EXPLODE IF A FLAME OR SPARK IGNITES THE HYDROGEN GAS THE BATTERY EMITS WHILE BEING CHARGED.



CORROSION ALLOWED TO BUILD ON THE ELECTRICAL CONNECTORS CAN CAUSE A POOR CONNECTION RESULTING IN SHORTS, GROUND FAULTS OR POOR GROUND CONNECTIONS. ELECTRICAL CONNECTORS SHOULD CHECKED AT LEAST ANNUALLY AND CLEANED AS REQUIRED. DO NOT ALLOW CORROSION TO BUILD ON CONNECTIONS.



THE ELECTRICAL SYSTEM ALWAYS SHOULD BE DISCONNECTED FROM THE POWER SOURCE BEFORE INSPECTING OR SERVICING THE SYSTEM. NEVER SERVICE ANY COMPONENT OF AN ELECTRICAL SYSTEM WHILE IT IS ENERGIZED.

**THIS PAGE WAS LEFT BLANK
INTENTIONALLY**

Chapter 5:

FRESHWATER SYSTEM

5.1 General

The freshwater system consists of a potable water tank, distribution lines and a distribution pump. The tank is filled through a labeled deck plate located on the side of the center console. An in-line strainer located near the pump protects the system from debris.



DO NOT FILL SYSTEM WITH ANYTHING OTHER THAN WATER. SHOULD THE SYSTEM BECOME CONTAMINATED WITH FUEL OR OTHER TOXIC FLUIDS, COMPONENT REPLACEMENT MAY BE NECESSARY.



DO NOT CONFUSE FUEL FILL DECK PLATES WITH THE WATER OR WASTE FILL DECK PLATES. THESE PLATES ARE ALSO LABELED ACCORDINGLY. IF GASOLINE OR DIESEL FUEL IS ACCIDENTALLY PUMPED INTO THE WATER OR WASTE TANK, DO NOT ATTEMPT TO PUMP IT OUT YOURSELF. WATER AND WASTE PUMPS ARE NOT DESIGNED TO PUMP FUEL AND A FIRE OR EXPLOSION COULD RESULT. CONTACT YOUR DEALER OR THE PURSUIT CUSTOMER RELATIONS DEPARTMENT FOR ASSISTANCE IN HAVING THE FUEL PROFESSIONALLY REMOVED AND COMPONENTS OF THE FRESHWATER SYSTEM REPLACED AS NECESSARY.

5.2 Freshwater System Operation

Fill the water supply tank slowly through the labeled deck plate.

After filling the water tank, partially open all faucets. The freshwater switch on the 12-volt panel should be on. Allow the pump to run until all of the air is purged from the system and a steady stream of water is flowing from each outlet. Next, turn off the faucets one by one. As the pressure builds the pump will automatically shut off.

When properly primed and activated the water system will operate much like the water system in a home. An automatic pressure sensor keeps the system pressurized. If the system has been recently filled or has not been used for an extended period, air bubbles may accumulate at the pump and the system may have to be reprimed. Whenever the boat is left unattended, the freshwater pump switch should be placed in the “OFF” position.



Freshwater Pump



DO NOT ALLOW THE FRESHWATER PUMP TO RUN DRY. THIS CAN RESULT IN DAMAGE TO THE PUMP.

5.3 Freshwater System Maintenance

Information supplied with water system components, by the equipment manufacturers, is included with this manual. Refer to this information for additional operation and service data.

The following items should be done routinely to maintain your Freshwater System:

Periodically, remove the water tank vent and clean corrosion and salt buildup from the vent screens. The screens will prevent insects and other foreign matter from contaminating the water system. The vent should be replaced if the vent or screens are damaged or badly corroded. Vent screens that are clogged will prevent the water tank from venting properly and make filling the tank difficult.

Be sure the screens are secure and that the vent hose is properly routed and attached when the vent is reinstalled or replaced. The vent hose must be looped above the vent, secured to the hull near the vent and securely attached to the vent hose fitting with a hose clamp.

Remove the filter screens from the faucet spouts and eliminate any accumulation of debris. A build up of debris can cause the pump to cycle excessively.

The freshwater system is equipped with a strainer located on the intake line near the pump. This should be checked at least annually and cleaned as necessary.

Periodically spray the pumps and metal components with a metal protector.

Add a commercially available potable water conditioner to the water tank to keep it fresh.



THE BATTERIES MUST BE PROPERLY CHARGED. OPERATING THE FRESHWATER PUMP FROM A BATTERY WITH A LOW CHARGE MAY LEAD TO A PUMP FAILURE.

Chapter 6:

RAW WATER SYSTEM

6.1 General

In the raw or sea water systems, all water pumps are supplied by a hose connected to a ball valve located in the bilge compartment. Always make sure the ball valves are open before attempting to operate any component of the raw water system.

12-volt pumps supply sea water to the various accessories.

Priming the System

Make sure the ball valves are open. Open the hose connector for the raw water washdown and activate the pressure pump by turning the washdown pump switch to the “ON” position. Run the pump until all of the air is purged from the system and then turn the switch off. Turn the livewell switch to the “ON” position and run the pump until all of the air is purged from the system and then turn the switch to the “OFF” position. Closing the thru-hull ball valves before the boat is hauled from the water will help to eliminate air locks in raw water systems.

Note: It may be necessary to reprime the raw water system if the system is not used for an extended period and at the time of launching.

6.2 High Pressure Washdown

A saltwater high pressure pump, controlled by a pressure sensor, supplies the raw water hose connector located in the cockpit. The pump is activated by the washdown switch located in the helm or the rear of the cockpit. This switch should be turned to the “ON” position just before using the washdown and be turned to the “OFF” position when the washdown is not in use.

When activated, the pressure switch will automatically control the pump. As the pressure builds in the washdown hose, the pump will shut off. When the washdown hose is in use and the pressure drops, the pump will turn on.

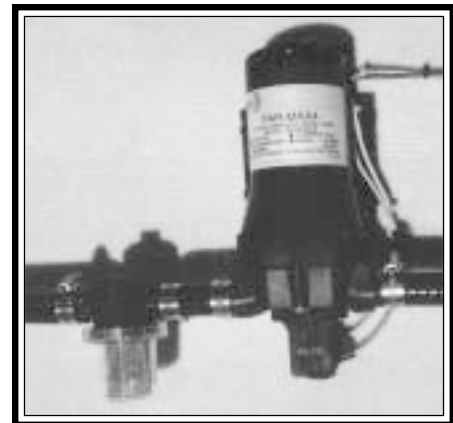

Washdown Pump

The raw water washdown system is equipped with a sea strainer located on the intake side of the pump. This should be checked frequently and cleaned as necessary.

The Washdown Pump Connection

The washdown pump hose connection is located in the cockpit and uses a standard garden hose connection.

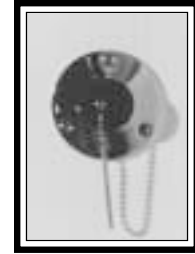

Washdown Hose Connector



ALWAYS TURN THE RAW WATER PUMP SWITCH TO THE “OFF” POSITION WHEN LEAVING THE BOAT UNATTENDED.



DO NOT RUN THE HIGH PRESSURE PUMP DRY FOR EXTENDED PERIODS AS DAMAGE TO THE PUMP WILL RESULT.

6.3 Livewell

Sea water is provided to the livewell by a 12-volt circulation pump. This pump is designed to carry a constant flow of water to the livewell. The pump is not equipped with a pressure sensor and is activated by the livewell switch in the 12-volt panel or a separate switch in the cockpit. A light in the livewell is also activated by the livewell switch.

An overflow built into the livewell automatically controls the water level in the livewell. Always turn the pump “OFF” at the switch panel when the livewell is not in use.



Livewell

To fill the livewell, insert the plug into the drain fitting at the bottom of the livewell. Make sure the valve at the intake thru-hull fitting is open and activate the livewell switch. When the water level reaches the overflow, it will begin to circulate.

To drain the livewell, turn off the livewell pump and pull out the plug in the drain fitting at the bottom of the livewell. When the livewell has completely drained, use the washdown hose to flush the livewell and drain of debris.

The livewell supply thru-hull valve should be closed whenever the livewell is not in use. This will prevent water from entering the livewell while the boat is cruising.

The livewell system is equipped with a sea strainer on the intake side of the pump located in the bilge behind the stern access hatch. This should be checked frequently and cleaned as necessary.

Note: Do not use the livewell as a dry storage area when it is not in use. Sea water could accidentally be delivered to the livewell from the thru-hull and damage equipment stored there.

6.4 Raw Water System Maintenance

The following items should be done routinely to help maintain your raw water system:

- Check hoses, particularly the sea water supply line, for signs of deterioration.
- Remove and clean the sea water strainers.
- Spray pumps and thru-hull valves with a protective oil periodically.
- The fishboxes and livewells should be drained and cleaned after each use.
- Operate all thru-hull valves at least once a month to keep them operating properly.

The light assembly for the livewell is accessed from below the cockpit and through an access hatch located near the livewell. If the bulb needs replacing, reach through the access hatch and carefully work the socket out of the light assembly. The wire should be long enough to pull the socket and bulb out of the access hatch. Apply a thin layer of petroleum jelly to the base of the new bulb and insert it into the socket. Care must be taken not to get any oil or petroleum jelly on the glass portion of the bulb as this will cause the bulb to overheat and burn out. Insert the bulb and socket into the light assembly.



SHOULD A HOSE RUPTURE, TURN THE PUMP OFF IMMEDIATELY. ALWAYS CLOSE THE THRU-HULL VALVE WHEN PERFORMING MAINTENANCE ON A SEA WATER PUMP.



THE BATTERIES MUST BE PROPERLY CHARGED. OPERATING ANY PUMPS FROM A BATTERY WITH A LOW CHARGE MAY LEAD TO A PUMP FAILURE.



THE RAW WATER SYSTEM MUST BE PROPERLY WINTERIZED PRIOR TO WINTER LAY-UP. SEE SECTION ON WINTERIZING.

Chapter 7: DRAINAGE SYSTEMS

7.1 Cockpit Drainage

Your Pursuit has two scupper drains located on each side of the hull near the waterline to provide drainage for the cockpit. Water is channeled away from all opening hatches by a gutter or drain rail system. The water then drains overboard through the scuppers.

The scupper drain thru-hull fittings are equipped with PVC ball valves that are always open under normal operating conditions. The valves are accessed through hatches located in the stern. In the event of an emergency, the valves can be closed to prevent seawater from entering the boat through the drainage system. It is important to check and operate the drain valves at least annually to make sure they are in good condition and operating properly. You also should check the drain system frequently to ensure it is free flowing and that the hoses on the thru-hull fittings are secure and not leaking.

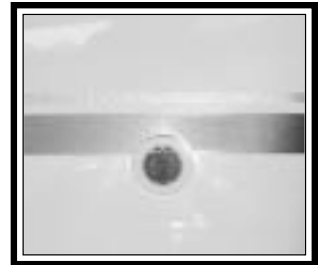

Scupper

Please review the drainage schematic to become familiar with the location of the thru-hull drain valves.



SITUATIONS REQUIRING ONE OR MORE DRAIN VALVES TO BE CLOSED CAN BE POTENTIALLY DANGEROUS TO THE BOAT AND YOUR CREW. IF THIS OCCURS, DISTRIBUTE PERSONAL FLOTATION DEVICES TO THE CREW AND TAKE ALL NECESSARY SAFETY PRECAUTIONS, INCLUDING NOTIFYING THE COAST GUARD, UNTIL THE PROBLEM IS FOUND AND CORRECTED.

7.2 Leaning Post and T-Top Drainage

There is a hole drilled in one of the leg bases to prevent water from being trapped within the leg and provide a wire chase for accessories. A small hole is drilled in the tubing at the base of legs that are not drilled for a wire chase, to allow water to drain.



ALWAYS MAKE SURE THE LEG DRAIN HOLES ARE CLEAR WHEN THE BOAT IS LAID UP FOR THE WINTER. WATER TRAPPED INSIDE THE T-TOP OR LEANING POST LEGS COULD FREEZE AND CAUSE THE LEGS TO SPLIT.

7.3 Bilge Drainage

The bilge pump is activated both manually, by a switch in the helm station, and automatically by a float switch located next to the pump in the bilge. The automatic float switch remains activated when the battery switch is in the “OFF” position. All bilge pumps pump water out of thru-hulls located above the waterline in the hull.

Note: See Electrical Systems for additional information on bilge pump operation.

IMPORTANT: Any oil spilled in the bilge must be thoroughly removed and properly disposed of before operating the bilge pump. The discharge of oil from the bilge is illegal and subject to a fine.



THE FEDERAL WATER POLLUTION CONTROL ACT PROHIBITS THE DISCHARGE OF OIL OR OILY WASTE INTO OR UPON THE NAVIGABLE WATERS OF THE UNITED STATES OR THE WATERS OF THE CONTIGUOUS ZONE IF SUCH DISCHARGE CAUSES A FILM OR SHEEN UPON, OR A DISCOLORATION OF THE SURFACE OF THE WATER, OR CAUSES A SLUDGE OR EMULSION BENEATH THE SURFACE OF THE WATER. VIOLATORS ARE SUBJECT TO A PENALTY OF \$5,000.



CERTAIN BULKHEAD AREAS ARE SEALED IN ACCORDANCE WITH U.S. COAST GUARD REGULATIONS THAT WERE IN EFFECT AT THE DATE OF MANUFACTURE OF THE BOAT. ANY MODIFICATIONS TO THESE BULKHEADS SHOULD BE IN ACCORDANCE WITH THE U.S. COAST GUARD REGULATIONS.

7.4 Fishbox and Storage Compartment Drainage

The fishbox and storage compartment located in the bow are drained by gravity. The fishbox drains overboard out of a thru-hull fitting located in the hull side above the waterline and the bow storage box drains into the bilge.

7.5 Sink and Livewell Drains

All sinks and livewells, provided with fresh or raw water, drain by gravity to overboard thru-hulls located in the hull sides just above the waterline. The overflows in the livewells drain into the overboard drains.

7.6 Console Cooler Drain

The console cooler is drained by gravity. Water is channeled from the cooler to the cockpit sole and then overboard through the scuppers. The cooler should be flushed out and cleaned after each use.

7.7 Maintenance

It is essential that the following items be done periodically to maintain proper drainage of your boat:

- Clean the cockpit drain rails with a hose to remove debris that can block water drainage.
- Operate the thru-hull valves once a month and service as required.
- Clean the T-top leg drain holes. This is especially important just before winter lay-up.
- Clean the bilge pump strainers of debris and check the bilge for foreign material that can cause the automatic switches to malfunction.
- Frequently test the automatic bilge pump switch for proper operation. This is accomplished by inserting a stiff wire or small rod through one of the slots in the float chamber of the pump and lifting the float switch until the pump turns on. You can also use a hose to flood the bilge until the water level is high enough to activate the pump.
- Flush all gravity drains with fresh water to keep them clean and free flowing.
- Clean and flush the fishboxes and coolers with soap and fresh water or a bilge cleaner after each use to keep them clean and fresh.



ALL DRAINS AND PUMPS MUST BE PROPERLY WINTERIZED BEFORE WINTER LAY-UP.



NEVER USE HARSH CHEMICAL DRAIN CLEANERS IN MARINE DRAIN SYSTEMS. PERMANENT DAMAGE TO THE HOSES AND FITTINGS MAY RESULT.

**THIS PAGE WAS LEFT BLANK
INTENTIONALLY**

Chapter 8: EXTERIOR EQUIPMENT

8.1 Deck

Rails and Deck Hardware

The rail system and hardware fittings have been selected and installed to perform specific functions. Fenders or mooring lines should be secured to the cleats and not to rails or stanchions. Mooring lines should be secured to the stern cleats. Be sure a clear lead exists when running dock lines or anchor lines. A line inadvertently run around a stanchion or over the rail could cause damage.

IMPORTANT: All fittings must be periodically inspected for loose fit, wear and damage. Any problems should be corrected immediately.



PURSUIT BOATS ARE NOT EQUIPPED WITH HARDWARE DESIGNED FOR TOWING PURPOSES. THE MOORING CLEATS ARE NOT TO BE USED FOR TOWING ANOTHER VESSEL OR HAVING THIS BOAT TOWED.

Bow Pulpit and Roller (Optional)

The bow pulpit can be equipped with a roller assembly that allows the anchor to be operated and stored at the pulpit. The anchor line is stored in the rope locker and routed out the rope locker hatch, through the roller and connected to the anchor chain. Always make sure the anchor is properly secured when it is in the stored position on the pulpit.



Bow Pulpit and Roller

Anchor/Rope Locker

The anchor locker is in the bow of the boat and accessed through a hatch in the deck. The anchor line is always stored in the locker. The anchor can be mounted on the optional bow pulpit or stored in the anchor locker. If the anchor is stored in the anchor locker it must be properly secured to prevent it from bouncing in the locker and causing damage to the hull or anchor locker.

The anchor locker is drained to the bilge by a drain in the floor of the locker. It is very important to check the drain frequently to make sure it is clean and free flowing.



Anchor/Rope Locker



THE ANCHOR MUST BE POSITIONED SO IT DOES NOT REST AGAINST THE HULL SIDES AND BE PROPERLY SECURED AT ALL TIMES WHEN IT IS STORED IN THE ANCHOR/ROPE LOCKER. A LOOSE ANCHOR IN THE ANCHOR LOCKER WILL BOUNCE AND CAN DAMAGE THE BOAT. DAMAGE RESULTING FROM THE ANCHOR BOUNCING IN THE ANCHOR LOCKER IS NOT COVERED BY THE PURSUIT WARRANTY.

Windlass (Optional)

The optional windlass is mounted to the deck near the rear of the pulpit above the rope locker. The anchor is stored on the pulpit and is raised and lowered by the windlass. The anchor line is stored in the rope locker and routed out through the windlass to the anchor chain.

The anchor is lowered by releasing the anchor from the cleat or chain binder on the pulpit and operating a “down” control at the helm. The windlass control switch is activated by a safety circuit breaker in a panel located next to the windlass switch. Raise the lever on the breaker to reset the breaker and activate the windlass control switch. Push the red button to return the breaker to “OFF” whenever the windlass is not in use. This breaker is provided to protect the windlass electrical circuit and reduce the possibility of accidentally activating the windlass.

After the anchor is set, the windlass must not be left to take the entire force from the anchor line. Boats lying to their anchor in a high swell or heavy weather conditions will snub on the line. This can cause slippage or apply excessive loads to the windlass. The line should be made fast to a bow cleat to relieve the load on the windlass.

The anchor is hauled in by releasing the line from the bow cleat and operating the “up” control at the helm. Once the anchor is retrieved, independently secure the anchor to the chain binder or a cleat to prevent it from being accidentally released. This is especially important while the boat is under way.

The windlass manufacturer provides an owner’s manual with its product. It is extremely important that you read the manual and become familiar with the proper care and operation of the windlass.



A WINDLASS MUST BE USED WITH CARE. IT IS EXTREMELY IMPORTANT THAT YOU READ THE OWNER’S MANUAL AND BECOME FAMILIAR WITH THE SAFETY INSTRUCTIONS AND PROPER OPERATION OF THE WINDLASS BEFORE USING IT WITH YOUR BOAT. ALWAYS ENSURE THAT LIMBS, FINGERS, HAIR AND CLOTHING ARE KEPT CLEAR OF THE WINDLASS AND ANCHOR LINE DURING OPERATION.



DO NOT USE A WINDLASS AS A SOLE MEANS OF SECURING AN ANCHOR IN THE BOW PULPIT. ALWAYS SECURE THE ANCHOR LINE TO A CLEAT OR CHAIN BINDER BEFORE OPERATING YOUR BOAT.

8.2 Hull

Swim Platform

Your Pursuit is equipped with an integral swim platform and engine mounting system located in the stern of the boat. There are two inspection deck plates in the transom engine well to provide access to the stern bilge and engine mounting bolts. Always make sure these plates are secure before operating your boat.

Boarding Ladder (Optional)

The optional boarding ladder is mounted to the rear of the stern bait and tackle rigging station when it is in the stored position. To use the ladder, remove it from the storage clips and slide the studs into the special bracket on the port side of the transom. The ladder floats and must be secured in the boarding position by turning the cam lock on the ladder so it catches the bottom of the transom ladder bracket. The ladder must be removed from the transom bracket and properly secured to the storage clips before starting the engine(s).



MOVING PROPELLERS ARE DANGEROUS. THEY CAN CAUSE DEATH, LOSS OF LIMBS, OR OTHER SEVERE INJURY. DO NOT USE THE SWIM PLATFORM OR SWIM LADDER WHILE THE ENGINE(S) ARE RUNNING. STOP THE ENGINE(S) IF DIVERS OR SWIMMERS ARE ATTEMPTING TO BOARD. ALWAYS REMOVE AND PROPERLY STORE THE LADDER BEFORE STARTING THE ENGINE(S).

8.3 Cockpit Equipment



IN CERTAIN CONDITIONS, OPEN EXTERIOR DOORS AND HATCHES THAT ARE NOT SECURED PROPERLY CAN SLAM CLOSED UNEXPECTEDLY AND CAUSE INJURY TO PASSENGERS OR DAMAGE TO THE BOAT. MOST DOORS AND HATCHES ARE EQUIPPED WITH SPECIAL FASTENERS, HATCH LIFTERS, OR SNAPS AND/OR STRAPS, TO SECURE THEM IN THE OPEN POSITION. ALWAYS MAKE SURE THAT THESE HATCHES AND DOORS ARE PROPERLY SECURED WHENEVER THEY ARE IN THE OPEN POSITION.

Bow Storage Compartment and Fishbox

There is a large fishbox located under the port bow hatch. This is drained overboard by gravity and can be used as a fishbox or storage compartment. When this box is used as a fishbox, it should be drained and cleaned after each use. A large storage compartment is located under the starboard bow hatch. This compartment is drained into the bilge and is intended for dunnage.

Leaning Post/Baitwell

The leaning post/baitwell is equipped with rod holders, a leaning post cushion, and a circulating livewell. The livewell is supplied by a raw water aerator pump and drains overboard. Refer to chapter 6 for additional information on the raw water system.

Stern Bait and Tackle Rigging Station

The stern bait and tackle rigging station is equipped with a sink, removable cutting board, fishbox, tackle locker and rigged bait storage area. The sink is plumbed to the freshwater system. Refer to chapter 6 for additional information on the raw water system.



Removable Tackle Locker

The tackle locker is below the fishbox and is removable to allow access to the bilge, Y-valve, and the port battery. To remove the tackle locker, open the door and remove the top drawer. Remove the quick release pin on the upper port side of the tackle locker and slide the locker forward out of the frame.

Transom Door

A transom door is incorporated into the rigging station. The transom door should only be opened when the boat is not in motion. The door must be latched in either the full “OPEN” or full “CLOSED” position. Never leave the transom door unlatched.

Note: Periodically inspect the transom door fittings for wear, damage, or loose fit. Any problems should be inspected and corrected immediately.



THE TRANSOM DOOR SHOULD BE CLOSED AND PROPERLY LATCHED WHENEVER THE ENGINE(S) ARE RUNNING. NEVER OPEN THE TRANSOM DOOR WHILE UNDERWAY OR IN ROUGH SEA CONDITIONS. IN CERTAIN SITUATIONS, AN OPEN TRANSOM DOOR COULD ALLOW A SUBSTANTIAL AMOUNT OF WATER TO ENTER THE COCKPIT CREATING A POTENTIALLY DANGEROUS CONDITION.



OPERATING THE BOAT UNDER POWER WITH THE TRANSOM DOOR OPEN MAY ALLOW PERSONS TO FALL OVERBOARD AND INTO BOAT PROPELLERS OR TO BE LOST IN OPEN WATER. ALWAYS CHECK TO MAKE SURE THE TRANSOM DOOR IS PROPERLY CLOSED AND LATCHED BEFORE STARTING THE ENGINES AND NEVER OPERATE THE BOAT UNDER POWER WITH THE TRANSOM DOOR OPEN.

8.4 Center Console

Helm and Electronics Locker

The helm and engine controls are located on the rear of the center console. Molded-in electronics storage is located forward of the engine controls.

The top section of the console is hinged and opens to provide access to service the helm equipment or to install electronics. To open the helm portion of the console, release the clamps on the front of the console. The front of the console can then be lifted to expose the underside of the helm. A strap holds the helm in the open position and prevents it from opening too far. Always make sure the helm station clamps are properly secured when the helm is closed.



ALWAYS MAKE SURE THE HELM STATION CLAMPS ARE PROPERLY SECURED BEFORE OPERATING OR TRAILERING YOUR BOAT. IF THE HELM STATION IS NOT PROPERLY SECURED, IT COULD OPEN UNEXPECTEDLY AND DAMAGE THE BOAT OR CAUSE LOSS OF CONTROL.



UNDER NO CIRCUMSTANCES SHOULD THE HELM BE OPENED WHEN THE ENGINE(S) ARE RUNNING. IN SOME SITUATIONS IT IS POSSIBLE TO ACCIDENTALLY ENGAGE THE ENGINE SHIFT AND THROTTLE CONTROL INTO GEAR AS THE HELM IS OPENING. THIS COULD RESULT IN LOSS OF CONTROL, DAMAGE TO THE BOAT, AND INJURY TO PASSENGERS.

Head Compartment

The head compartment is located in the console. A door in the starboard side of the console provides access to the head. The porta potti or head and the freshwater pump are among the equipment mounted in this compartment. Refer to Interior Equipment chapter for information on the equipment in the head compartment.

Console Cooler

A molded insulated cooler is installed under the front seat of the console. The cooler drains to the cockpit sole through a fitting in the side of the console. The cooler should be cleaned thoroughly after each use.

T-top (Optional)

The Pursuit T-top is made of welded anodized aluminum and is designed to accommodate radio antennas, radar antennas and navigation lights. It is equipped with an overhead storage compartment for life jackets and other soft, light items and a courtesy light activated by a switch in the helm. It could also be equipped with optional top gun outriggers and / or rod holders.

The T-top is not designed to support the additional weight of items like an instrument locker or a life raft. Radar and electronics antennas must be mounted near the center section of the T-top in the area above the legs. Do not mount any antennas or equipment to the brow area forward of the front legs or to the rear of the top. The T-top is not design to support the weight of accessories in these areas.

The warranty for the T-top will be void if the top is modified in any way or heavy accessories like life rafts, or electronics lockers are mounted to the top. Additionally, if items like radar antennas spotlights and other accessories are mounted in the wrong location, the warranty could be void. If you intend to add equipment or make modifications to the T-top, you should contact Pursuit

Customer Relations to make sure the equipment you would like to add or the intended modification will not void the warranty on the T-top.

If an after market T-top is installed, it must be designed with four legs that are bolted to the cockpit sole near the front and rear sides of the center console. There are aluminum plates laminated below the cockpit sole that can be drilled and tapped to secure the T-top leg bases in these areas. Both front and rear legs should also have brackets that are thru bolted to the console just below the hinged helm section to provide additional stiffening for the T-top. Avoid a T-top that is designed to mount only on the center console because it will cause excessive flexing to the console and cockpit sole which will result in stress cracks and fractures in the fiberglass. If you have any questions about installing a T-top on your boat, please contact your dealer or Pursuit Customer Relations.

Chapter 9: INTERIOR EQUIPMENT

9.1 Portable Head

The system is made up of two major components, an upper tank and a lower tank. The upper tank contains the freshwater supply, a bellows pump, a seat and the lid. The bottom tank contains the flush valve, a waste holding tank, a chemical storage compartment and the drain nozzle. The components are secured together by a clamping mechanism when the portable head is ready for use.

In some areas the law requires that portable heads be equipped with an optional permanent deck mounted pump out system to evacuate the waste with a dock side pump. Boats with a portable head pump out will be equipped with a deck fitting marked “waste” located on the deck. Since this system is required to be permanent, the bottom waste tank cannot be removed and the only way to evacuate the system is by a dock side pump.



Portable Head

To use the portable head, add the recommended amount of holding tank deodorant to the waste tank and fill the freshwater tank. To flush after use, pull the waste valve handle straight out, then press the flushing bellows one or more times to rinse. To close and seal the waste holding tank, simply push the valve handle all the way in. Monitor the level in the waste tank and empty as necessary.

Maintenance

To keep your portable head operating properly it must be emptied and properly cleaned periodically. Please refer to the manufacturer owner’s manual for detailed instructions on the proper operation of your portable head.



IN SOME AREAS THE LAW REQUIRES A WASTE PUMP OUT SYSTEM ON PORTABLE HEADS. IF YOUR BOAT IS EQUIPPED WITH THE WASTE PUMP OUT, MAKE SURE YOU KNOW THE LAWS FOR THE AREAS IN WHICH YOU BOAT BEFORE MODIFYING OR REMOVING THE PUMP OUT SYSTEM.



THE PORTABLE HEAD MUST BE PROPERLY WINTERIZED BEFORE WINTER LAY-UP OR FOR COLD WEATHER USE. PLEASE REFER TO THE MANUFACTURER OWNER’S MANUAL FOR COLD WEATHER AND WINTERIZING INSTRUCTIONS.

9.2 Marine Head System (Optional)

This system is provided as optional equipment. The flush water is supplied by a thru-hull fitting and a raw water line. Before using, open the inlet valve on the head and pump to wet the inside of the bowl. After use, close the valve and pump to discharge the waste to the holding tank or overboard.

Waste can be directed either into the holding tank or overboard, when legal to do so. This is accomplished by an optional Y-valve located in the stern bilge below the tackle locker.



Marine Head

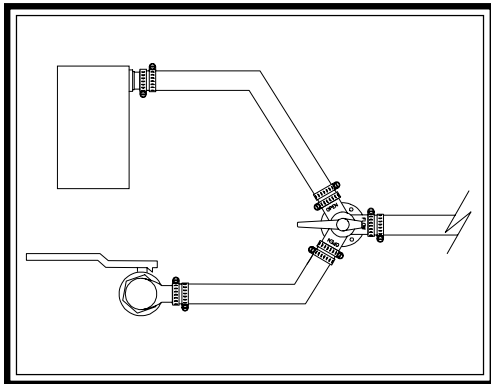

Y-Valve

In the overboard discharge position, the waste exits the boat through a large thru-hull fitting located in the stern bilge. The thru-hull fitting is equipped with a ball valve. Always open this valve when the overboard discharge is selected and close it when the holding tank is selected.

In the holding tank position, the waste is pumped directly into the holding tank where it remains until it is pumped out by a waste dumping station or the optional overboard discharge system.



IN MANY AREAS IT IS ILLEGAL TO FLUSH HEAD WASTE DIRECTLY OVERBOARD. VIOLATION OF THESE POLLUTION LAWS CAN RESULT IN FINES OR IMPRISONMENT. ALWAYS KNOW THE LAW FOR THE AREAS IN WHICH YOU BOAT. NEVER DUMP HEAD OR HOLDING TANK WASTE OVERBOARD ILLEGALLY.

Holding Tank

The holding tank is located in the bilge area. When the tank is full it must either be pumped out by an approved waste dumping station through the waste deck fitting or be pumped overboard with the optional macerator discharge pump, when legal to do so. When the macerator discharge pump is installed, the Y-valve will be used to select either the macerator discharge pump or the waste deck fitting to evacuate the holding tank.

To operate the macerator discharge pump, open the ball valve at the overboard discharge thru-hull and set the Y-valve to the macerator pump position. Then activate the momentary macerator switch, located in the stern below the battery switch, until the tank is emptied. Release the switch and close the discharge ball valve when pumping is complete.



DO NOT ALLOW THE OVERBOARD MACERATOR DISCHARGE PUMP TO RUN DRY FOR MORE THAN 10 SECONDS. SERIOUS DAMAGE TO THE MACERATOR PUMP WILL RESULT.

Maintenance

The head should be cleaned and inspected for leaks regularly.

The holding tank should be pumped out and flushed as needed. Periodically add chemical to the holding tank to help control odor and to chemically break down the waste. See the head manufacturer owner's manual for additional operating and maintenance information.

Periodically spray the macerator pump with a metal protector.



THE HEAD SYSTEM MUST BE PROPERLY WINTERIZED BEFORE WINTER LAY-UP. SEE SECTION ON WINTERIZING.

**THIS PAGE WAS LEFT BLANK
INTENTIONALLY**

Chapter 10: SAFETY EQUIPMENT

10.1 General

Your boat and outboard engine have been equipped with safety equipment designed to enhance the safe operation of the boat and to meet U.S. Coast Guard safety standards. The Coast Guard or state, county, and municipal law enforcement agencies require certain additional accessory safety equipment on each boat. This equipment varies according to length and type of boat and type of propulsion. The accessory equipment required by the Coast Guard is described in this chapter. Some local laws require additional equipment. It is important to obtain “Federal Requirements and Safety Tips for Recreational Boats,” published by the Coast Guard, and copies of state and local laws, to make sure you have the required equipment for your boating area. You should also read the book entitled “Sportfish, Cruisers and Yachts” included with your boat.

Your boat could be equipped with engine alarms. These systems are designed to increase your boating safety by alerting you to potentially serious problems in the primary power systems. Alarm systems are not intended to lessen or replace good maintenance and precruise procedures.

This chapter also describes safety related equipment that could be installed on your boat. This equipment will vary depending on the type of engine and other options installed by you or your dealer.

10.2 Engine Alarms

Most outboard engines are equipped with an audible alarm system mounted in the helm area that monitors selected critical engine systems. The alarm will sound if one of these systems begins to fail. Refer to the engine owner’s manual for information on the alarm installed with your engine.

If the alarm sounds:

- Immediately throttle the engine back to idle.
- Shift to neutral.
- Monitor the engine gauges to determine the cause of the problem.
- If necessary, shut off the engine and investigate until the cause of the problem is found.

10.3 Neutral Safety Switch

Every control system has a neutral safety switch incorporated into it. This device prohibits an engine from being started while the shift lever is in any position other than the neutral position. If the engine will not start, slight movement of the shift lever may be necessary to locate the neutral position and disengage the safety cutout switch. Control or cable adjustments may be required to correct this condition should it persist. See your Pursuit dealer for necessary control and cable adjustments. Please refer to the Helm Control Systems chapter for more information on the neutral safety switch.

10.4 Engine Stop Switch

Your Pursuit is equipped with a engine stop switch and lanyard. When the lanyard is pulled it will engage the switch and shut off the engine. We strongly recommend that the lanyard be attached to the driver whenever the engine is running. If the engine will not start, it could be because the lanyard is not properly inserted into the engine stop switch. Always make sure the lanyard is properly attached to the engine stop switch before attempting to start the engine.

10.5 Required Safety Equipment

Besides the equipment installed on your boat by Pursuit, certain other equipment is required by the U.S. Coast Guard to help ensure passenger safety. Items like a sea anchor, working anchor, extra dock lines, flare pistol, life vests, a line permanently secured to your ring buoy, etc. could at some time save your passengers' lives, or save your boat from damage. Refer to the "Federal Requirements and Safety Tips for Recreational Boats" pamphlet for a more detailed description of the required equipment. You can also contact the U.S. Coast Guard Boating Safety Hotline, 800-368-5647 or 800-336-2628 and 800-245-2628 in Virginia, for information on boat safety courses and brochures listing the Federal equipment requirements. Also, check your local and state regulations.

The Coast Guard Auxiliary offers a "Courtesy Examination." This inspection will help ensure that your boat is equipped with all of the necessary safety equipment.

The following is a list of the accessory equipment required on your boat by the U.S. Coast Guard:

Personal Flotation Devices (PFDs)

PFDs must be Coast Guard approved, in good and serviceable condition, and of appropriate size for the intended user. Wearable PFDs must be readily accessible, meaning you must be able to put them on in a reasonable amount of time in an emergency. Though not required, the Coast Guard emphasizes that PFDs should be worn at all times when the vessel is underway. Throwable devices must be immediately available for use. All Pursuit boats must be equipped with at least

one Type I, II or III PFD for each person on board, plus one throwable device (Type IV). Some states have special PFD requirements for children. Make sure you know and follow the laws for your boating area.

Visual Distress Signals

All Pursuit boats used on coastal waters, the Great Lakes, territorial seas, and those waters connected directly to them, must be equipped with Coast Guard approved visual distress signals. These signals are either Pyrotechnic or Non-Pyrotechnic devices.

Pyrotechnic Visual Distress Signals

Pyrotechnic visual distress signals must be Coast Guard approved, in serviceable condition, and readily accessible. They are marked with a date showing the service life, which must not have expired. A minimum of three are required. Some pyrotechnic signals meet both day and night use requirements. They should be stored in a cool, dry location. They include:

- Pyrotechnic red flares, hand held or aerial.
- Pyrotechnic orange smoke, hand-held or floating.
- Launchers for aerial red meteors or parachute flares.



PYROTECHNICS ARE UNIVERSALLY RECOGNIZED AS EXCELLENT DISTRESS SIGNALS. HOWEVER, THERE IS POTENTIAL FOR INJURY AND PROPERTY DAMAGE IF NOT PROPERLY HANDLED. THESE DEVICES PRODUCE A VERY HOT FLAME AND THE RESIDUE CAN CAUSE BURNS AND IGNITE FLAMMABLE MATERIAL. PISTOL LAUNCHED AND HAND-HELD PARACHUTE FLARES AND METEORS HAVE MANY CHARACTERISTICS OF A FIREARM AND MUST BE HANDLED WITH CAUTION. IN SOME STATES THEY ARE CONSIDERED A FIREARM AND PROHIBITED FROM USE. ALWAYS BE EXTREMELY CAREFUL AND FOLLOW THE MANUFACTURER'S INSTRUCTIONS EXACTLY WHEN USING PYROTECHNIC DISTRESS SIGNALS.

Non-Pyrotechnic Devices:

Non-Pyrotechnic visual distress signals must be in serviceable condition, readily accessible, and certified by the manufacturer as complying with U.S. Coast Guard requirements. They include:

- **Orange Distress Flag. (Day use only)**
The distress flag is a day signal only. It must be at least 3 x 3 feet with a black square and ball on an orange background. It is most distinctive when attached and waved from a paddle or boat hook.
- **Electric Distress Light. (Night use only)**
The electric distress light is accepted for night use only and must automatically flash the international SOS distress signal. Under Inland Navigation Rules, a high intensity white light flashing at regular intervals from 50-70 times per minute is considered a distress signal.

Fire Extinguishers

At least one fire extinguisher is required on all Pursuit boats. Boats 26' and larger may require two or three fire extinguishers. Coast Guard approved fire extinguishers are hand-portable, either B-I or B-II classification and have a specific marine type mounting bracket. It is recommended the extinguishers be mounted in a readily accessible position.

Fire extinguishers require regular inspections to insure that:

- Seals & tamper indicators are not broken or missing.
- Pressure gauges or indicators read in the operable range.
- There is no obvious physical damage, corrosion, leakage or clogged nozzles.

Contact the U.S. Coast Guard Boating Safety Hotline, 1-800-368-5647, for information on the type and size fire extinguisher required for your boat.

Please refer to the information provided by the fire extinguisher manufacturer for instructions on the proper maintenance and use of your fire extinguisher.



INFORMATION FOR HALON OR AGENT FE-241 FIRE EXTINGUISHERS IS PROVIDED BY THE MANUFACTURER. IT IS ESSENTIAL THAT YOU READ THE INFORMATION CAREFULLY AND COMPLETELY UNDERSTAND THE SYSTEM, IN THEORY AND OPERATION, BEFORE USING YOUR BOAT.

Bilge and Fuel Fires

Fuel compartment and bilge fires are very dangerous because of the presence of gasoline in the various components of the fuel system and the possibility for explosion. You must make the decision to fight the fire or abandon the boat. If the fire can not be extinguished quickly or it is too intense to fight, abandoning the boat may be your only option. If you find yourself in this situation, make sure all passengers have a life preserver on and go over the side and swim well upwind of the boat. This will keep you and your passengers well clear of any burning fuel that could be released and spread on the water as the boat burns or in the event of an explosion. When clear of the danger, check about and account for all those who were aboard with you. Give whatever assistance you can to anyone in need or in the water without a buoyant device. Keep everyone together in a group for morale and to aid rescue operations.



GASOLINE CAN EXPLODE. IN THE EVENT OF A FUEL COMPARTMENT OR BILGE FIRE, YOU MUST MAKE THE DIFFICULT DECISION TO FIGHT THE FIRE OR ABANDON THE BOAT. YOU MUST CONSIDER YOUR SAFETY, THE SAFETY OF YOUR PASSENGERS, THE INTENSITY OF THE FIRE AND THE POSSIBILITY OF AN EXPLOSION IN YOUR DECISION.

10.6 First Aid

It is the operator's responsibility to be familiar with the proper first-aid procedures and be able to care for minor injuries or illnesses of your passengers. In an emergency, you could be far from professional medical assistance. We strongly recommend that you be prepared by receiving training in basic first aid and CPR. This can be done through classes given by the Red Cross or your local hospital.



Your boat should also be equipped with at least a simple marine first-aid kit and a first-aid manual. The marine first-aid kit should be designed for the marine environment and be well supplied. It should be accessible and each person on board should be aware of its location. As supplies are used, replace them promptly. Some common drugs and antiseptics may lose their strength or become unstable as they age. Ask a medical professional about the supplies you should carry and the safe shelf life of prescription drugs or other medical supplies that may be in your first-aid kit. Replace questionably old supplies whether they have been used or not.

In many emergency situations, the Coast Guard can provide assistance in obtaining medical advice for treatment of serious injuries or illness. If you are within VHF range of a Coast Guard Station, make the initial contact on channel 16 and follow their instructions.

10.7 Additional Safety Equipment

Satellite EPIRBs

EPIRBs (Emergency Position Indicating Radio Beacon) operate as part of a worldwide distress system. When activated, EPIRBs will send distress code homing beacons that allow Coast Guard aircraft to identify and find them quickly. The satellites that receive and relay EPIRB signals are operated by the National Oceanic and Atmospheric Administration (NOAA) in the United States. The EPIRB should be mounted and registered according to the instructions provided with the beacon, so that the beacon's unique distress code can be used to quickly identify the boat and owner.

Additional Equipment to Consider:

| | | |
|-----------------|-----------------|-------------------|
| VHF Radio | Life Raft | Spare Anchor |
| Heaving Line | Fenders | First Aid Kit |
| Flashlight | Mirror | Searchlight |
| Sunburn Lotion | Tool Kit | Ring Buoy |
| Whistle or Horn | Anchor | Chart and Compass |
| Boat Hook | Spare Propeller | Mooring Lines |
| Food & Water | Binoculars | Sunglasses |
| Marine Hardware | Extra Clothing | Spare Parts |

10.8 Maximum Capacity Rating

Your boat is equipped with a “Maximum Capacities” plate, which is permanently attached to the cockpit near the helm. The plate indicates the maximum horsepower and load capacity for your boat. Never exceed the limits dictated by the information provided on the capacity plate.



IT IS EXTREMELY DANGEROUS TO OVERLOAD OR OVERPOWER YOUR BOAT. BOATS THAT ARE OVERLOADED OR OVERPOWERED CAN BECOME UNSTABLE OR DIFFICULT TO CONTROL. ALWAYS MAKE SURE THAT YOUR BOAT IS LOADED AND POWERED WITHIN THE LIMITS SHOWN ON YOUR BOAT'S CAPACITY PLATE.

Chapter 11: OPERATION

11.1 General

Before you start the engines on your Pursuit, you should have become familiar with the various component systems and their operation, and have performed a “Pre-Cruise System Check.” A thorough understanding of the component systems and their operation is essential to the proper operation of the boat. This manual and the associated manufacturers’ information is provided to enhance your knowledge of your Pursuit. Please read them carefully. Also read the book titled “Sportfish, Cruisers and Yachts,” included in your literature packet.

Your boat must have the necessary safety equipment on board and be in compliance with the U.S. Coast Guard, local and state safety regulations. There should be one Personal Floatation Device (PFD) for each person. Nonswimmers and small children should wear PFDs at all times. You should know and understand the “Rules of the Road” and have had an experienced operator brief you on the general operation of your new boat. At least one other person should be instructed on the proper operation of the boat in case the operator is suddenly incapacitated.

The operator is responsible for his safety and the safety of his passengers. When boarding or loading the boat, always step onto the boat, never jump. All passengers should be properly seated whenever the boat is operated above idle speed. Your passengers should not be allowed to sit on the seat backs, gunnels, bows, transoms or on fishing seats whenever the boat is underway. The passengers should also be seated to properly balance the load and must not obstruct the operator's view, particularly to the front.

Overloading and improper distribution of weight can cause the boat to become unstable and are significant causes of accidents. Know the weight capacity and horsepower rating of your boat. Do not overload or overpower your boat. Please refer to the Safety Equipment chapter for more information on the maximum capacity rating for your boat. **Remember, the information stated on the capacity plate does not relieve the operator from the responsibility of using good common sense and sound judgment in loading and operating the boat.**

11.2 Rules of the Road

As in driving an automobile, there are a few rules you must know for safe boating operation. The following information describes the basic navigation rules and action to be taken by vessels in a crossing, meeting or overtaking situation while operating in inland waters. These are basic examples and not intended to teach all the rules of navigation. For further information consult the “Navigation Rules” or contact the Coast Guard, Coast Guard Auxiliary, Department of

Natural Resources, or your local boat club. These organizations sponsor courses in boat handling, including rules of the road. We strongly recommend such courses. Books on this subject are also available from your local library.



SAILBOATS NOT UNDER POWER, PADDLE BOATS, VESSELS UNABLE TO MANEUVER, VESSELS ENGAGED IN COMMERCIAL FISHING AND OTHER VESSELS WITHOUT POWER HAVE THE RIGHT OF WAY OVER MOTOR POWERED BOATS. YOU MUST STAY CLEAR OR PASS TO THE STERN OF THESE VESSELS. SAILBOATS UNDER POWER ARE CONSIDERED MOTOR BOATS.

Crossing Situations

When two motor boats are crossing, the boat on the right has the right of way. The boat with the right of way should maintain its course and speed. The other vessel should slow down and permit it to pass. The boats should sound the appropriate signals.

Meeting Head-On or Nearly-So Situations

When two motor boats are approaching each other head-on or nearly head-on, neither boat has the right of way. Both boats should reduce their speed and turn to the right so as to pass port side to port side, providing enough clearance for safe passage. The boats should sound the appropriate signals.

Overtaking Situations

When one motor boat is overtaking another motor boat, the boat that is being passed has the right of way. The overtaking boat must make the adjustments necessary to provide clearance for a safe passage of the other vessel. The boats should sound the appropriate signals.

The General Prudential Rule

In obeying the Rules of the Road, due regard must be given to all dangers of navigation and collision, and to any special circumstances, including the limitations of the vessels, which may justify a departure from the rules that is necessary to avoid immediate danger or a collision.

Navigation Aids

Aids to navigation are placed along coasts and navigable waters as guides to mark safe water and to assist mariners in determining their position in relation to land and hidden dangers. Each aid to navigation is used to provide specific information. You should be familiar with these and any other markers used in your boating area.



STORMS AND WAVE ACTION CAN CAUSE BUOYS TO MOVE. YOU SHOULD NOT RELY ON BUOYS ALONE TO DETERMINE YOUR POSITION.

11.3 Pre-Cruise System Check

Before Starting the Engines

- Check the weather forecast. Decide if the planned cruise can be made safely.
- Be sure all required documents are on board.
- Be sure all necessary safety equipment is on board and operative. This should include items like the running lights, spotlight, life saving devices, etc. Please refer to the Safety Equipment chapter for additional information on safety equipment.
- Make sure you have signal kits and flare guns aboard, and they are current and in good operating condition.
- Be sure you have sufficient water and other provisions for the planned cruise.
- Leave a written message listing details of your planned cruise with a close friend ashore (Float Plan). The float plan should include a description of your boat, where you intend to cruise, and a schedule of when you expect to arrive in the cruising area and when you expect to return. Keep the person informed of any changes in your plan to prevent false alarms. This information will tell authorities where to look and the type of boat to look for in the event you fail to arrive.
- Check the amount of fuel on board. Observe the “rule of thirds”: one third of the fuel for the trip out, one third to return and one third in reserve. An additional 15% may be consumed in rough seas.
- Check the water separating fuel filters for water.
- Check the oil in the engine oil tanks.
- Set the battery selector switches as desired.
- Check the bilge water level. Look for other signs of potential problems. Monitor for the scent of fuel fumes.
- Test the automatic and manual bilge pump switches to make sure the system is working properly. The automatic bilge pump switch typically has a “test” knob, lever or access for a stiff wire to manually test the switch.

- Have a tool kit aboard. The kit should include the following basic tools:

| | |
|----------------------|--------------------|
| Spark Plug Wrench | Hammer |
| Spark Plug Gap Gauge | Electrician's Tape |
| Screwdrivers | Lubricating Oil |
| Pliers | Jackknife |
| Adjustable Wrench | Vise grip Pliers |
| Needle Nose Pliers | Wire Crimping Tool |
| End Wrench Set | Wire Connector Set |



THERE MUST BE AT LEAST ONE PERSONAL FLOTATION DEVICE ONBOARD FOR EVERY PERSON ON BOARD AND ONE THROW-OUT FLOTATION DEVICE. CHECK THE U.S. COAST GUARD STANDARDS FOR THE CORRECT TYPE OF DEVICE FOR YOUR BOAT.

- Have the following spare parts on board:

| | |
|----------------------------|--------------------------|
| Extra Light Bulbs | Spark Plugs |
| Fuses and Circuit Breakers | Flashlight and Batteries |
| Drain Plugs | Engine Oil |
| Propeller | Fuel Filters |
| Propeller Nuts | Fuel Hose and Clamps |

- Make sure all fire extinguishers are in position and in good operating condition.
- Be sure the shift control is in the neutral position.
- Be sure the emergency stop lanyard is attached to the operator and the stop switch.



VAPORIZING LIQUID EXTINGUISHERS GIVE OFF TOXIC FUMES; USE ONLY COAST GUARD APPROVED FIRE EXTINGUISHERS.

11.4 Operating Your Boat

After Starting the Engines



TO REDUCE THE RISK OF A FIRE OR EXPLOSION, DO NOT START THE ENGINES WHEN FUEL FUMES ARE PRESENT. FUEL FUMES ARE DANGEROUS AND HARMFUL TO YOUR HEALTH.

- Visibly check the engines to be sure there are no apparent water, fuel or oil leaks.
- Check the operation of the engine cooling systems.
- Check the engine gauges. Make sure they are reading normally.
- Check the controls and steering for smooth and proper operation.
- Make sure all lines, cables, anchors, etc. for securing a boat are on board and in good condition. All lines should be coiled, secured and off the decks when underway.
- Have a safe cruise and enjoy yourself.

Remember

When you operate a boat, you accept the responsibility for the boat, for the safety of passengers and for others out enjoying the water.

- Alcohol and any drugs can severely reduce your reaction time and affect your better judgment.
- Alcohol severely reduces the ability to react to several different signals at once.
- Alcohol makes it difficult to correctly judge speed and distance, or track moving objects.
- Alcohol reduces night vision, and the ability to distinguish red from green.



YOU SHOULD NEVER OPERATE YOUR BOAT WHILE UNDER THE INFLUENCE OF ALCOHOL AND DRUGS.

- Avoid sea conditions that are beyond the skill and experience of you and your crew.



MAKE SURE ONE OTHER PERSON ON THE BOAT IS INSTRUCTED IN THE OPERATION OF THE BOAT.



MAKE SURE THE BOAT IS OPERATED IN COMPLIANCE WITH ALL STATE AND LOCAL LAWS GOVERNING THE USE OF A BOAT.



DO NOT OPERATE THE BOAT UNLESS IT IS COMPLETELY ASSEMBLED. KEEP ALL FASTENERS TIGHT. KEEP ADJUSTMENTS ACCORDING TO SPECIFICATIONS.

Before operating the boat for the first time, read the engine break-in procedures. The break-in procedures are found in the owner's manual for the engine. The manual is in the literature packet.

As different types of engines are used to power the boat, have the dealer describe the operating procedures for your boat. For more instructions on "How To Operate The Boat," make sure you read the instructions given to you in the owner's manual for the engines you have selected.

Note: For more instructions on safety, equipment and boat handling, enroll in one of the several free boating courses offered. For information on the courses offered in your area, call the "Boating Course Hotline," 1-800-336-2628.

Note: If the drive unit hits an underwater object, stop the engine. Inspect the drive unit for damage. If the unit is damaged, contact your dealer for a complete inspection and repair of the unit.

To stop the boat, follow this procedure:

- Allow the engine to drop to the idle speed.
- Make sure the shifting levers are in the neutral position.

Note: If the engines have been run at high speed for a long period of time, allow the engines to cool down by running the engines in the idle position for 3 to 5 minutes.

- Turn the ignition keys to the "Off" position.
- Raise the trim tabs to the full "UP" position.

After Operation

- If operating in saltwater, wash the boat and all equipment with soap and water. Flush the engines using freshwater. Please refer to the engine owner's manual for instructions on flushing your outboard engines.
- Check the bilge area for debris and excess water.
- Fill the fuel tanks to near full to reduce condensation. Allow enough room in the tank for the fuel to expand without being forced out through the vent.
- Turn off all electrical equipment except the automatic bilge pumps.
- If you are going to leave the boat for a long period of time, put the battery main switches in the “Off” position and close all seacocks.
- Make sure the boat is securely moored.



TO PREVENT DAMAGE TO THE BOAT, CLOSE ALL SEA COCKS BEFORE LEAVING THE BOAT.

11.5 Grounding and Towing

If the boat should become disabled, or if another craft that is disabled requires assistance, great care must be taken. The stress applied to a boat during towing may become excessive. Excessive stress can damage the structure of the boat and create a safety hazard for those aboard.

Freeing a grounded vessel, or towing a boat that is disabled, requires specialized equipment and knowledge. Line failure and structural damage caused by improper towing have resulted in fatal injuries. Because of this, we strongly suggest that these activities be left to those who have the equipment and knowledge, e.g., the U.S. Coast Guard or a commercial towing company, to safely accomplish the towing task.



THE MOORING CLEATS ON PURSUIT BOATS ARE NOT DESIGNED OR INTENDED TO BE USED FOR TOWING PURPOSES. THESE CLEATS ARE SPECIFICALLY DESIGNED AS MOORING CLEATS FOR SECURING THE BOAT TO A DOCK, PIER, ETC. DO NOT USE THESE FITTINGS FOR TOWING OR ATTEMPTING TO FREE A GROUNDED VESSEL.



WHEN TOWING OPERATIONS ARE UNDERWAY, HAVE EVERYONE ABOARD BOTH VESSELS STAY CLEAR OF THE TOW LINE AND SURROUNDING AREA. A TOW LINE THAT SHOULD BREAK WHILE UNDER STRESS CAN BE VERY DANGEROUS, AND COULD CAUSE SERIOUS INJURY OR DEATH.



RUNNING AGROUND OR STRIKING AN UNDERWATER OBSTRUCTION CAN RESULT IN SERIOUS INJURY TO PASSENGERS AND DAMAGE TO THE MOTOR OR BOAT. IF YOUR BOAT SHOULD BECOME GROUNDED, DISTRIBUTE PERSONAL FLOTATION DEVICES AND INSPECT THE BOAT FOR POSSIBLE DAMAGE. THOROUGHLY INSPECT THE BILGE AREA FOR SIGNS OF LEAKAGE. AN EXPERIENCED SERVICE FACILITY SHOULD CHECK YOUR UNDERWATER GEAR AT THE FIRST OPPORTUNITY. DO NOT CONTINUE TO USE YOUR BOAT IF THE CONDITION OF THE UNDERWATER EQUIPMENT IS QUESTIONABLE.

11.6 Water Skiing

Your boat could be equipped for water skiing. If you have never driven skiers before, you should spend some hours as an observer and learning from an experienced driver. If you are an experienced driver, you should take some time to become familiar with the boat and the way it handles before pulling a skier. The driver should also know the skier's ability and drive accordingly. The following safety precautions should be observed while towing water skiers.

- Water ski only in safe areas, away from other boats and swimmers, out of channels, and in water free of underwater obstructions.
- Water ski only during daylight hours.
- Make sure that anyone who skis can swim. Do not allow people who cannot swim to water ski.
- Be sure that the skier is wearing a proper life jacket. A water skier is considered on board the boat and a Coast Guard approved life jacket is required. It is advisable and recommended for a skier to wear a flotation device designed to withstand the impact of hitting the water at high speed.
- Always carry a second person on board to observe the skier so that your full attention can be given to the safe operation of the boat.
- Approach a skier in the water from the downwind side and be certain to stop the motion of the boat and your motor before coming in close proximity to the skier. The skier should also be kept on the helm side of the boat so the operator can keep the skier in sight at all times.

- Give immediate attention to a fallen skier. A fallen skier is very hard to see by other boats and is extremely vulnerable. When a skier falls, be prepared to immediately turn the boat and return to the skier. Never leave a fallen skier alone in the water for any reason.

For additional information on water skiing, including hand signals and water skiing manuals, contact the American Water Skiing Association in Winter Haven, Florida, 863-324-4341.



MOVING PROPELLERS ARE DANGEROUS. THEY CAN CAUSE DEATH, LOSS OF LIMBS, OR OTHER SEVERE INJURY. DO NOT USE THE SWIM PLATFORM OR SWIM LADDER WHILE THE ENGINE IS RUNNING. STOP THE ENGINE IF DIVERS, SWIMMERS OR SKIERS ARE ATTEMPTING TO BOARD. ALWAYS REMOVE AND PROPERLY STORE THE LADDER BEFORE STARTING THE ENGINE.

11.7 Fishing

Fishing can be very exciting and distracting for the operator when the action gets intense. You must always be conscious of the fact that your primary responsibility is the safe operation of your boat and the safety of your passengers and other boats in the area.

You must always make sure the helm is properly manned and is never left unattended while trolling.

If you are fishing in an area that is crowded with other fishing boats, it may be difficult to follow the rules of the road. This situation can become especially difficult when most boats are trolling. Being courteous and exercising good common sense is essential. Avoid trying to assert your right of way and concentrate on staying clear and preventing tangled or cut lines and other unpleasant encounters with other boats. Also keep in mind that fishing line wrapped around your propeller shaft can damage the seals in the outboard lower unit.

11.8 Trailering Your Boat

If you trailer your boat, make sure that your tow vehicle is capable of towing the weight of the trailer, boat and equipment and the weight of the passengers and equipment inside the vehicle. This may require that the tow vehicle be specially equipped with a larger engine, transmission, brakes and trailer tow package.

The boat trailer is an important part of your boating package. The trailer should be matched to your boat's weight and hull. Using a trailer with a capacity too low will be unsafe on the road and cause abnormal wear. A trailer with a capacity too high, can damage the boat. Contact your dealer to evaluate your towing vehicle and hitch, and to make sure you have the correct trailer for your boat.

Important Note:

Your Pursuit is a heavy boat and care must be taken when selecting the trailer. We recommend that you use a bunk style trailer that incorporates a combination of heavy duty rollers, to support the keel and long bunks running under and parallel to the stringers to support the hull. Avoid using a full roller trailer that does not have bunks. Roller trailers have a tendency to put extreme pressure points on the hull, especially on the lifting strakes, and have damaged boats. The situation is worse during launching and haul out. Damage resulting from improper trailer support or the use of a full roller trailer will not be covered by the Pursuit Warranty.

Note: Contact your dealer to evaluate your towing vehicle and hitch, and to make sure you have the correct trailer for your boat.

The following safety tips and a book titled “Sportfish, Cruisers, Yachts - Owner’s Manual,” included in your literature packet, provide additional information you should know before trailering your boat.

Choosing and setting up a trailer:

- Make sure the trailer is a match for your boat’s weight and hull design. More damage can be done to a boat by the stresses of road travel than by normal water operation. A boat hull is designed to be supported evenly by water. So, when it is transported on a trailer it should be supported structurally as evenly across the hull as possible allowing for even distribution of the weight of the hull, engine and equipment.
- Make sure the trailer bunks and rollers properly support the hull and do not put pressure on the lifting strakes. The rollers and bunks must be kept in good condition to prevent scratching and gouging of the hull.
- The capacity rating of the trailer should be greater than the combined weight of the boat, motor, and equipment. The gross vehicle weight rating must be shown on the trailer. Make sure the weight of the boat, engine, gear and trailer is not more than the gross vehicle weight rating.
- Make sure the boat is securely fastened on the trailer to prevent movement between the boat and trailer. The bow eye on the boat should be secured with a rope, chain or turnbuckle in addition to the winch cable. Additional straps may be required across the beam of the boat.

Note: Your dealer can provide instructions on how to load, fasten and launch your boat.

BOATS HAVE BEEN DAMAGED BY TRAILERS THAT DO NOT PROPERLY SUPPORT THE HULL.



ALWAYS MAKE SURE THE TRAILER BUNKS AND ROLLERS ARE ADJUSTED SO THEY ARE NOT PUTTING EXCESSIVE PRESSURE ON THE LIFTING STRAKES AND ARE PROVIDING ENOUGH SUPPORT FOR THE HULL. HULL DAMAGE RESULTING FROM IMPROPER TRAILER SUPPORT IS NOT COVERED BY THE PURSUIT WARRANTY.

Before Going Out On The Highway:

- The BIMINI TOP, SIDE CURTAINS, CLEAR CONNECTOR, BACK DROP and AFT CURTAIN must be removed when trailering. Canvas enclosures are not designed to withstand the extreme wind pressure encountered while trailering and will be damaged. Always remove and properly store the enclosure before trailering your boat.
- Make sure the tow BALL and COUPLER are the same size and bolts nuts are tightly secured.
- The COUPLER MUST BE COMPLETELY OVER THE BALL and the LATCHING MECHANISM LOCKED DOWN.
- Make sure the TRAILER IS LOADED EVENLY from front to rear as well as side to side and has the correct weight on the hitch. Too much weight on the hitch will cause the rear of the tow vehicle to drag and may make steering more difficult. Too little weight on the hitch will cause the rig to fishtail and will make controlling the tow vehicle difficult. Contact your Pursuit dealer or the trailer manufacturer for the correct weight on the hitch for your trailer.
- The SAFETY CHAINS must be attached crisscrossing under the coupler to the frame of the tow vehicle. If the ball was to break, the trailer would follow in a straight line and prevent the coupler from dragging on the road. Make sure the trailer emergency brake cable or chain is also installed to the tow vehicle frame.
- Make sure the LIGHTS on the trailer function properly.
- CHECK THE BRAKES. On a level parking area roll forward and apply the brakes several times at increasing speeds to determine if the brakes on the tow vehicle and trailer are working properly.
- Make sure the tow vehicle has SIDE VIEW MIRRORS that are large enough to provide an unobstructed rear view on both sides of the vehicle.
- CHECK THE TIRES and WHEEL BEARINGS.



MAKE SURE YOUR TOWING VEHICLE AND TRAILER ARE IN COMPLIANCE WITH ALL STATE AND LOCAL LAWS. CONTACT YOUR STATE MOTOR VEHICLE BUREAU FOR LAWS GOVERNING THE TOWING OF TRAILERS.

**THIS PAGE WAS LEFT BLANK
INTENTIONALLY**

Chapter 12:

ROUTINE MAINTENANCE

12.1 Exterior Hull and Deck

Hull Cleaning-Below The Water Line

When the boat is removed from the water, clean the outer bottom surface immediately. Algae, grass, dirt and other marine growth is easier to remove while the hull is still wet. Use a pressure cleaner or a hard bristle brush to clean the surface.

Bottom Painting

If the boat is to be left in saltwater for extended periods, the hull must be protected from marine growth by antifouling paint. Because of variations in water temperature, marine growth, and pollution in different regions, your dealer and/or a qualified boat yard in your area should be consulted when deciding what bottom paint system to apply to your hull. This is extremely important as pollution and marine growth can damage fiberglass hulls.



SANDING OR SANDBLASTING THE HULL BOTTOM WILL DAMAGE THE FIBERGLASS. USE ONLY STANDARD ANTIFOULING PAINTS AND FIBERGLASS WAX REMOVERS AND PRIMERS RECOMMENDED BY THE ANTIFOULING PAINT MANUFACTURER WHEN PREPARING THE HULL FOR BOTTOM PAINT. SANDING OR SANDBLASTING AND THE USE OF A COATING OTHER THAN STANDARD ANTIFOULING PAINT OR EPOXY BARRIER COATINGS ARE NOT RECOMMENDED AND WILL VOID THE FIVE YEAR HULL BLISTER WARRANTY.

Do not allow the hull antifouling paint to contact the outboard motor. Most antifouling paints designed for hull bottoms contain copper and can cause severe galvanic damage to the motor. Always leave a 1/2" barrier between the hull bottom paint and outboard motor.

Most bottom paints require some maintenance. Proper maintenance is especially important when the boat is in saltwater and not used for extended periods or after dry storage. If the hull bottom has been painted with antifouling paint, contact your dealer or the paint manufacturer for the recommended maintenance procedures.

Anodes

Sacrificial anodes are installed on the outboard engines and should be installed on the trim tabs if the boat is to be left in the water. The anodes are less noble than copper based alloys and aluminum and will deteriorate first, protecting the more noble underwater hardware against galvanic corrosion. Anodes should be checked monthly and changed when they are 75% of their original size. When replacing the anodes, make sure the contact surfaces are clean, shiny metal and free of paint and corrosion. Never paint over the anodes.

Fiberglass Gelcoat Surfaces

Normal maintenance requires only washing with mild soap and water. A stiff brush can be used on the nonskid areas. Kerosene or commercially prepared products will remove oil and tar which could be a problem on trailered boats. Harsh abrasive and chemical cleaners are not recommended because they can damage or dull the gelcoat, reducing its life and making it more susceptible to stains. When the boat is used in saltwater, it should be washed thoroughly with soap and water after each use.

At least once a season, wash and wax all exposed fiberglass surfaces. Use a high quality automotive or boat wax. Follow the procedure recommended by the wax manufacturer. The washing and waxing of your boat will have the same beneficial effects as they have on an automobile finish. The wax will fill minute scratches and pores thus helping to prevent soiling and will extend the life of the gelcoat.

After the boat is exposed to the direct sunlight for a period of time, the color in the gelcoat tends to fade, dull or chalk. A heavier buffing is required to bring the gelcoat back to its original luster. For power cleaning, use a light cleaner such as Mirror Glaze # 1®. To clean the boat by hand, use a heavier automotive cleaner. Before cleaning the surfaces, read the instructions given with the cleaner. After cleaning the surfaces, apply wax, and polish all fiberglass surfaces except the nonskid areas.

If the fiberglass should become damaged and need repair, contact your dealer for an authorized repair person to do the work.



DO NOT WAX NONSKID AREAS AS THIS COULD MAKE THEM SLIPPERY AND CONSEQUENTLY INCREASE THE POSSIBILITY OF INJURY.

Stainless Steel Hardware

When using the boat in saltwater, the hardware should be washed with soap and water after each use. When your boat is used in a corrosive environment such as saltwater, water with a high sulfur content, or polluted water, the stainless steel will periodically develop surface rust stains. This is perfectly normal under these conditions. The stainless can normally be cleaned and protected by using a high quality boat or automotive wax or a commercial metal cleaner and protectant.



UNDER NO CIRCUMSTANCES SHOULD ANY ABRASIVE MATERIALS SUCH AS SANDPAPER, BRONZE WOOL, OR STEEL WOOL BE USED ON STAINLESS STEEL. DAMAGE TO THE HARDWARE WILL RESULT.

Anodized Aluminum Surfaces

Anodized aluminum should be washed periodically with soap and water to keep it clean. If the boat is used in saltwater or polluted water, the aluminum should be washed with soap and water after each use. Saltwater allowed to remain on anodized aluminum will penetrate the anodized coating and attack the aluminum.

T-tops, tops with aluminum frames, and towers with canvas and/or fiberglass tops require special attention to the anodized aluminum just below the top. This area is subject to salt build up from salty condensation and sea spray. It is also frequently overlooked when the boat is washed and will not be rinsed by the rain. Consequently, the aluminum just below the top is more likely to become pitted than the exposed aluminum on the structure. Make sure the aluminum in this area is washed frequently with soap and water and rinsed thoroughly. Pay particular attention to places where the top material and lacing contact the frame. Once a month coat the entire frame with a metal protector made for anodized aluminum to protect against pitting and corrosion caused by the harsh effects of salt water. The anodized aluminum used on your Pursuit was coated with a metal protector called Aluma Guard at the factory. Aluma Guard is a nonabrasive marine metal protector that protects anodized aluminum, stainless steel, brass, and chrome. It also protects color anodizing from fading and discoloring due to harmful ultraviolet rays. It is available from Rupp Marine Inc., 4761 Anchor Avenue, P.O. Drawer F, Port Salerno, FL 34992.



ONE DRAWBACK TO ALUMA GUARD AND OTHER METAL PROTECTORS IS THAT THEY CAN MAKE THE METAL SLIPPERY. THEREFORE, THEY SHOULD BE NOT BE USED ON TOWER LADDERS, STEERING WHEELS AND OTHER AREAS WHERE A GOOD GRIP AND SURE FOOTING IS IMPORTANT.

Stains can be removed with a metal polish or fine polishing compound. To minimize corrosion, use a caulking compound to bed hardware and fasteners mounted to aluminum fabrications. If the anodized coating is badly scratched it can be touched up with paint. With proper care, anodized aluminum will provide many years of service.

Chrome Hardware

Use a good chrome cleaner and polish on all chrome hardware.

Acrylic Plastic Glass

Acrylic glass scratches easily. Use a soft cloth and mild soap and water to clean acrylic. Solvents and products containing ammonia can permanently damage acrylic. A coat of automotive or boat wax is beneficial to protect the surface. Do not use the following on acrylic:

| | |
|-------------------|-----------------------------|
| Abrasive cleaners | Acetone |
| Solvents | Alcohol |
| Glass cleaners | Cleaners containing ammonia |

Engines

Proper engine maintenance is essential to the proper performance and reliability of your outboard engines. Maintenance schedules and procedures are outlined in your engine owner's manual. They should be followed exactly.

If the boat is used in saltwater, flush the cooling systems after each daily use. To flush the systems when the boat is out of the water, follow the procedure outlined in your engine owner's manual.

The age of gasoline can affect engine performance. Chemical changes occur as the gasoline ages that can cause deposits and varnish in the fuel system as well as reduce the octane rating of the fuel. Severely degraded fuel can damage the engine and boat fuel tank and lines. Therefore, if your boat is not being run enough to require at least one full tank of fresh fuel a month, a fuel stabilizer should be added to the gasoline to protect the fuel from degradation. Your dealer or the engine manufacturer can provide additional information on fuel degradation and fuel stabilizers recommended for your engine.

Avoid using fuels with alcohol additives. Gasoline that is an alcohol blend will absorb moisture from the air which can reach such concentrations that "phase separation" can occur whereby the water and alcohol mixture becomes heavy enough to settle out of the gasoline to the bottom of the tank. Since the fuel pickup tube is very near the bottom of the tank, phase separation can cause the engine to run very poorly or not at all. This condition is more severe with methyl alcohol and will worsen as the alcohol content increases. Water or a jelly like substance in the fuel filters are an indication of possible phase separation from the use of alcohol blended fuels.

12.2 Upholstery, Canvas and Enclosures

Vinyl Upholstery

The vinyl upholstery used on the exterior seats and bolsters, and for the headliner in some cabins, should be cleaned periodically with soap and water. Any stain, spill or soiling should be cleaned up promptly to prevent the possibility of permanent staining. When cleaning, always rub gently. Avoid using products containing ammonia, powdered abrasive cleaners, steel wool, ink, strong solvents, acetone and lacquer solvents or other harsh chemicals as they can cause permanent damage or shorten the life of vinyl. Never use steam heat, heat guns or hair dryers on vinyl.

Stronger cleaners, detergents and solvents may be effective in stain removal, but can cause either immediate damage or slow deterioration. Lotions, sun tan oil, waxes and polishes, etc., contains oils and dyes that can cause stiffening and staining of vinyls.

- Dry soil, dust and dirt - Remove with a soft cloth.
- Dried on dirt - Wash with a soft cloth dampened with water.
- Variations in surface gloss - Wipe with a water dampened soft cloth and allow to air dry.
- Stubborn dirt - Wash with a soft cloth dampened with Ivory Flakes® and water. Rinse with clean water.

- Stubborn spots and stains - Spray with either Fantastik Cleaner® or Tannery Car Care Cleaner® and rub with a soft cloth. Rinse with clean water.
- Liquid spills - Wipe immediately with a clean absorbent cloth. Rinse with clean water.
- Food grease and oily stains - Spray immediately using either Fantastik Cleaner® or Tannery Car Care Cleaner®, wiping with a soft cloth. Take care not to extend the area of contamination beyond its original boundary. Rinse with clean water.

Acrylic Canvas

Acrylic canvas should be cleaned periodically by using a mild soap and water. Scrub lightly and rinse thoroughly to remove the soap. Do not use detergents. The top or accessories should never be folded or stored wet.

After several years, the acrylic canvas may lose some of its ability to shed water. If this occurs, wash the fabric and treat it with a commercially available water proofing designed for this purpose.

Note: Some leakage at the seams is normal and unavoidable with acrylic enclosures.

Side curtains and clear connectors can be cleaned with mild soap and water. They should not be allowed to become badly soiled. Dirt, oil, mildew, and cleaning agents containing ammonia, will shorten the life of the vinyl that is used for clear curtains. After cleaning the curtains and allowing them to dry, apply a non-lemon furniture polish or an acrylic glass and clear plastic protector to extend the life of the curtains.

Vinyl curtains should be stored either rolled or flat, without folds or creases. Folding the curtains will make permanent creases that could cause the vinyl to crack.



DO NOT USE ANY POLISH CONTAINING LEMON SCENTS OR LEMON. THE LEMON JUICE WILL ATTACK THE VINYL AND SHORTEN ITS LIFE.

Snaps should be lubricated periodically with petroleum jelly or silicone grease. Zippers should be lubricated with silicone spray or paraffin.

The T-top enclosure must be removed when transporting the boat. Canvas enclosures are not designed to withstand the extreme wind pressure encountered while trailering and will be damaged. Always remove and properly store the enclosure before trailering or having your boat transported by truck.

Strataglass

Strataglass® is a special coated vinyl that is used in the curtains for the T-top enclosure. The coating protects the vinyl glass and resists scratching. Waxes and plexiglas polishing compounds should not be used on strataglass as the protective coating prevents them from penetrating into the vinyl and they will build up on the surface. These products will create a hazy, greasy

appearance that will affect the clarity of the strataglass. Products that repel water, like Rainex[®], should not be used as they will not take well to the surface and could appear spotty and may also yellow or dull the Strataglass over time.

Strataglass can be cleaned by rinsing off dirt or salt deposits with fresh water, then washing with a clean cloth and mild soap. Chamoise dry to remove water spots and improve clarity. If a polish is accidentally used, use Windex[®] or its equivalent to remove it. While window cleaners will destroy the standard vinyl normally used in side curtains and clear connectors, it will not harm strataglass. Always roll down the curtains and snap in place at the end of each day so the curtains will maintain their shape and to minimize fold distortions.

Remember, the coating on strataglass is scratch resistant and not scratch proof. Always handle the curtains with care and never roll up curtains that are salty or dirty. If you have any questions about the clear curtains used on your boat, please contact the Pursuit Customer Relations Department.

The T-top enclosure must be removed when trailering. Canvas enclosures are not designed to withstand the extreme wind pressure encountered while trailering and will be damaged. Always remove and properly store the enclosure before trailering your boat.

12.3 Bilge

Periodically check the bilge pumps for proper operation and clean debris from the strainers and float switches. Inspect all hoses, clamps and thru-hulls for leaks and tightness on a regular basis.

To keep the bilge clean and fresh, it is recommended that you use a commercial bilge cleaner on a regular basis. Follow the directions carefully. All exposed pumps and metal components in the bilge should be sprayed periodically with a protector to reduce the corrosive effects of the high humidity always present in these areas.

Periodically check the bilge pumps for proper operation and clean debris from the strainers and float switches. Inspect all hoses, clamps and thru-hulls for leaks and tightness on a regular basis and operate all thru-hull valves at least once a month to keep them operating properly.

12.4 Drainage System

It is essential that the following items be done periodically to maintain proper drainage of your boat:

- Clean the cockpit drains with a hose to remove debris that can block water drainage.
- Clean the hardtop or T-top leg drain holes. This is especially important just before winter lay-up.

- Frequently test the automatic bilge pump switches for proper operation.
 - Flush all gravity drains with freshwater to keep them clean and free flowing.
- Note: All drains and pumps must be properly winterized before winter lay-up.



**NEVER USE HARSH CHEMICAL DRAIN CLEANERS IN MARINE DRAIN SYSTEMS.
PERMANENT DAMAGE TO THE HOSES AND FITTINGS MAY RESULT.**

**THIS PAGE WAS LEFT BLANK
INTENTIONALLY**

Chapter 13:

SEASONAL MAINTENANCE

13.1 Storage and Lay-up

Before Hauling

- The fuel tank should be left nearly full to reduce condensation that can accumulate in the fuel tank. Allow enough room in the tank for the fuel to expand without leaking out the vent. Moisture from condensation in the fuel tank can reach such concentrations that it becomes heavy enough to settle out of the gasoline to the bottom of the tank. Since fuel pickup tubes are located near the bottom of the tank, this accumulated moisture can cause the engine to run poorly or not at all after extended storage.

Chemical changes also occur as the gasoline ages that can cause deposits and varnish in the fuel system as well as reduce the octane rating of the fuel. Severely degraded fuel can damage the engine and boat fuel tank and lines.

Therefore, if your boat is not being run enough to require at least one full tank of fresh fuel a month or during winter storage, a fuel stabilizer should be added to the gasoline to help protect the fuel system from these problems. Operate the boat for at least 15 minutes after adding the stabilizer to allow the treated fuel to reach the engine.

Your dealer or the engine manufacturer can provide additional information on fuel degradation and fuel stabilizers recommended for your engine. For more recommendations for your specific area, check with your local Pursuit dealer.

- Drain water from the freshwater system.
- **Consult the engine owner's manual for detailed information on preparing the engines for storage.**

Lifting



BOATS CAN BE DAMAGED FROM IMPROPER LIFTING AND ROUGH HANDLING WHEN BEING TRANSPORTED BY LIFT TRUCKS. CARE AND PROPER HANDLING PROCEDURES MUST BE USED WHEN USING A LIFT TRUCK TO MOVE THE BOAT. NEVER ATTEMPT TO LIFT THE BOAT WITH A SUBSTANTIAL AMOUNT OF WATER IN THE BILGE.



SEVERE GELCOAT CRACKING OR MORE SERIOUS HULL DAMAGE CAN OCCUR DURING HAULING AND LAUNCHING IF PRESSURE IS CREATED ON THE GUNWALES (SHEER) BY THE SLINGS. FLAT, WIDE SLINGS AND SPREADERS LONG ENOUGH TO KEEP PRESSURE FROM THE GUNWALES IS ESSENTIAL. DO NOT ALLOW ANYONE TO HAUL YOUR BOAT WHEN THE SPREADERS ON THE LIFT ARE NOT WIDE ENOUGH TO TAKE THE PRESSURE OFF THE GUNWALES.

Supporting The Boat For Storage

A trailer, elevating lift or a well-made cradle is the best support for your boat during storage.

When storing the boat on a trailer for a long period:

- Make sure the rollers and pads properly support the hull of the boat and do not put pressure on the hull lifting strakes.
- Make sure the trailer is on a level surface and the bow is high enough so that water will drain from the bilge.
- Make sure the engines are in the down position.
- Check the tires once each season. Add enough air for the correct amount of inflation for the tires.

Note: Read the owner's manual for the trailer for the correct amount of inflation for the tires.

When storing the boat on a lift or cradle:

- The cradle must be specifically for boat storage.
- Make sure the lift or cradle is well supported with the bow high enough to provide proper drainage of the bilge.
- Make sure the engines are in the down position.
- The cradle or lift must be in the proper fore and aft position to properly support the hull. When the cradle is in the correct location, the bunks should match the bottom of hull and should not

be putting pressure on the lifting strakes.



BOATS HAVE BEEN DAMAGED BY TRAILERS, LIFTS AND CRADLES THAT DON'T PROPERLY SUPPORT THE HULL. ALWAYS MAKE SURE THE BUNKS AND ROLLERS ARE ADJUSTED SO THEY ARE NOT PUTTING PRESSURE ON THE LIFTING STRAKES AND ARE PROVIDING ENOUGH SUPPORT FOR THE HULL. HULL DAMAGE RESULTING FROM IMPROPER CRADLE OR TRAILER SUPPORT IS NOT COVERED BY THE PURSUIT WARRANTY.

Preparing The Boat For Storage

- Pump out the head. Flush the holding tank using clean soap, water and a deodorizer. Pump out the cleaning solution.
- If your boat is equipped with a portable marine head with a pump out, it must be pumped prior to lay-up. Flush the holding tank using clean soap, water and a deodorizer. Pump out the cleaning solution.
- Remove the bilge drain plug, if installed.
- Thoroughly wash the fiberglass exterior, especially the antifouling portion of the bottom. Remove as much marine growth as possible. Lightly wax the exterior fiberglass components.
- Remove all oxidation from the exterior hardware, and apply a light film of moisture-displacing lubricant.
- Remove the propeller(s) and grease the propeller shaft(s) using light waterproof grease.
- Remove the batteries and store in a cool place. Clean using clear, clean water. Be sure the batteries have sufficient water and clean terminals. Keep the batteries charged and safe from freezing throughout the storage period.
- Refer to the Electrical System chapter, for information on the maintenance of the D.C. electrical systems.
- Coat all faucets and exposed electrical components in the cockpit with a protecting oil.
- Clean out, totally drain and completely dry the fishboxes and livewells.
- Clean the exterior upholstery with a good vinyl cleaner and dry thoroughly.
- Remove as many cushions and open as many locker doors as possible. Leaving as many of these areas open as possible will improve the boat's ventilation during the storage period.

13.2 Winterizing

Freshwater System

The entire freshwater system must be completely drained. Disconnect all hoses, check valves, etc. and blow all the water from the system. Make sure the hot water heater and freshwater tank are completely drained. Use only very low air pressure when doing this to prevent possible system damage. Because of the check valve mechanism built in the pump, blowing the lines will not remove the water from the freshwater pump. Remove the inlet and outlet hoses on the pump. Turn the pump on and allow it to pump out any remaining water....about a cupful. A recommended alternative to the above-mentioned procedure is the use of commercially available non toxic, freshwater system antifreeze. After draining the potable water tank and lines, pour the antifreeze mixture into the freshwater tank, prime and operate the pump until the mixture flows from all freshwater faucets. Be sure to open all water faucets, including the freshwater spray head in the stern bait station sink. Make sure antifreeze has flowed through all of the freshwater drains. Refer to the Freshwater System chapter for additional information on the freshwater system.

Raw Water System

Completely drain the raw water systems. Disconnect all hoses and blow the water from the system. Use only very low air pressure when doing this to prevent possible system damage. Because of the check valve mechanism built in the raw water washdown and livewell pumps, blowing the lines will not remove the water from that raw water pump. Remove the inlet and outlet hoses on the pumps. Turn each pump on and allow it to pump out any remaining water....about a cupful. A recommended alternative to the above-mentioned procedure is the use of commercially available nontoxic, potable water system antifreeze. If potable water antifreeze is used, pour the mixture into a pail and put the raw water intake lines into the solution. Run the pumps one at a time until the antifreeze solution is visible at all raw water faucets and discharge fittings and drains. Be sure antifreeze has flowed through all of the raw water drains.

Portable Head

The portable head must be properly winterized by following the manufacturer's winterizing instructions in the portable head owner's manual.

Marine Toilet

The marine toilet must be properly winterized by following the manufacturer's winterizing instructions in the marine toilet owner's manual. Drain the intake and discharge hoses completely using low air pressure if necessary. The head holding tank and optional macerator discharge pump must be pumped dry and one gallon of potable water antifreeze poured into the tank through the deck waste pump out fitting. After the antifreeze has been added to the holding tank, open the overboard discharge valve and activate the macerator pump until the antifreeze solution is visible at the discharge thru-hull.

Note: Make sure you follow the marine toilet manufacturer's winterizing instructions exactly.

Bilge

Coat all metal components, wire busses, and connector plugs in the bilge with a protecting oil. It is also important to protect all pumps, seacocks and steering components.

The bilge pump and bilge pump lines must be completely free of water and dried out when the boat is laid-up for the winter in climates where freezing occurs. Compartments in the bilge that will not drain completely should be pumped out and then sponged until completely free of water. Dry the hull bilge and self-bailing cockpit troughs. Water freezing in these areas could cause damage.

T-Top

It is imperative that all drain holes in the legs are open and that the legs are completely free of water. Remove the canvas and thoroughly clean and store in a safe, dry place. Remove all electronics. Coat all wire connectors and bus bars in the helm compartment with a protecting oil. Remove the acrylic canvas and coat the aluminum with a metal protector like Aluma Guard® or wax.



ALWAYS MAKE SURE THE LEG DRAIN HOLES ARE CLEAR WHEN THE BOAT IS LAID UP FOR THE WINTER. WATER TRAPPED INSIDE THE HARDTOP OR RADAR ARCH LEGS COULD FREEZE AND CAUSE THE LEGS TO SPLIT.

Special Notes Prior To Winter Storage

If the boat will be in outside storage, properly support a storage cover and secure it over the boat. It is best to have a frame built over the boat to support the canvas. It should be a few inches wider than the boat so the canvas will clear the rails and allow passage of air. If this cover is fastened too tightly there will be inadequate ventilation and this can lead to mildew, moisture accumulation, etc. It is essential to fasten the canvas down securely so that the winds cannot remove it or cause chafing of the hull superstructure. Do not store the boat in a damp storage enclosure. Excessive dampness can cause electrical problems, corrosion, and excessive mildew.

Whenever possible, do not use the bimini top or convertible top canvas in place of the winter storage cover. The life of these canvases may be significantly shortened if exposed to harsh weather elements for long periods.



PLACING AN ELECTRIC OR FUEL BURNING HEATING UNIT IN THE BOAT CAN BE POTENTIALLY HAZARDOUS AND IS NOT RECOMMENDED.

Proper storage is very important to prevent serious damage to the boat. If the boat is to be stored indoors, make sure the building has enough ventilation. It is very important that there is enough ventilation both inside the boat and around the boat.

13.3 Recommissioning



DO NOT OPERATE THE BOAT UNLESS IT IS COMPLETELY ASSEMBLED. KEEP ALL FASTENERS TIGHT. KEEP ADJUSTMENTS ACCORDING TO SPECIFICATIONS.



IT IS IMPORTANT AND RECOMMENDED THE FITTING OUT PROCEDURE FOR THE MARINE GEAR BE DONE BY A QUALIFIED SERVICE PERSON. READ THE ENGINE OWNER'S MANUAL FOR THE RECOMMENDED PROCEDURE.



BEFORE LAUNCHING THE BOAT, MAKE SURE THE DRAIN PLUG IS INSTALLED.

Reactivating The Boat After Storage:

- Charge and install the batteries.
- Install the drain plug in the hull.
- Check the engines for damage and follow the manufacturer's instructions for recommissioning.
- Check the engine mounting bolts to make sure they are tight.
- Perform all routine maintenance.
- Check all hose clamps for tightness.
- Pump the antifreeze from the fresh and raw water systems and flush several times with freshwater.
- Check and lubricate the steering system.
- Clean and wash the boat.
- Install all upholstery, cushions and canvas.

After Launching:

- Carefully check all water systems and the engine bolts for leaks. Operate each system one at a time checking for leaks and proper operation.
- Check the bilge pump manual and automatic switches.
- Prime the fuel system and start the engines. When the engines start, check the cooling system port below the engine cowling for a strong stream of water. This insures that the cooling pump is operating.
- Carefully monitor the gauges and check for leakage and abnormal noises.
- Operate the boat at slow speeds until the engine temperature stabilizes and all systems are operating normally.

**THIS PAGE WAS LEFT BLANK
INTENTIONALLY**

Chapter 14: SCHEMATICS

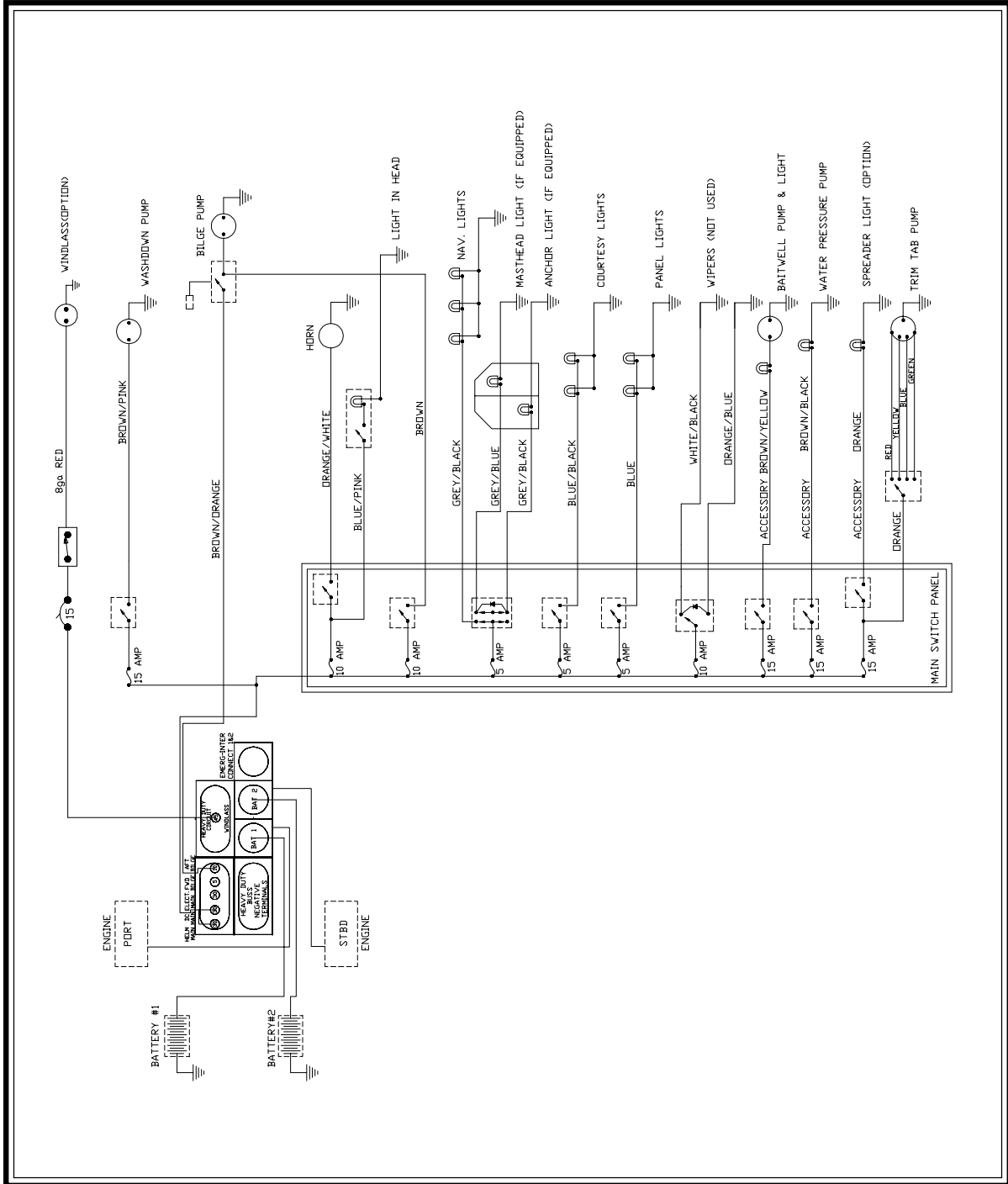

Twin Engine 12-Volt Wiring Schematic

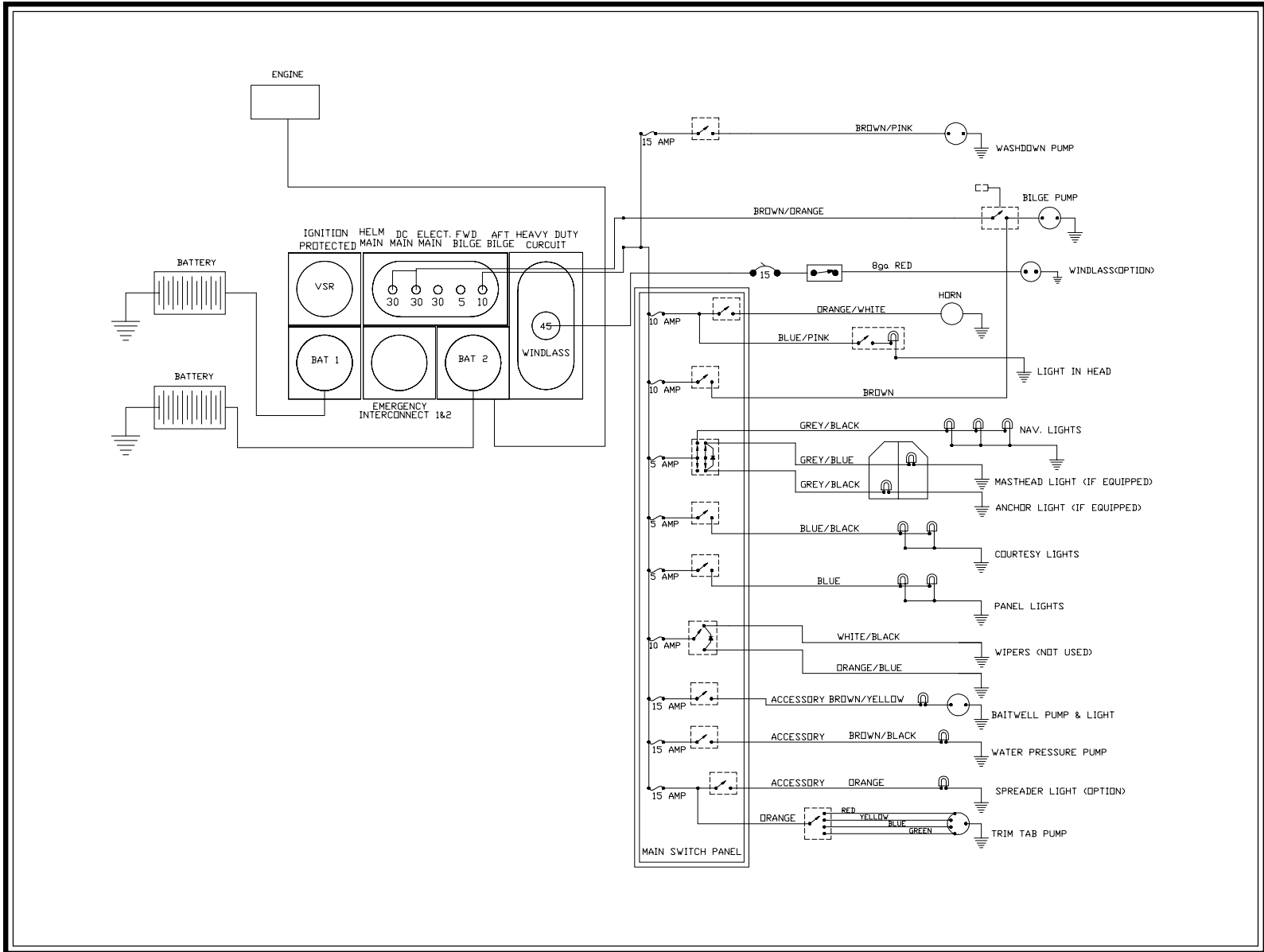

Single Engine 12-Volt Wiring Schematic

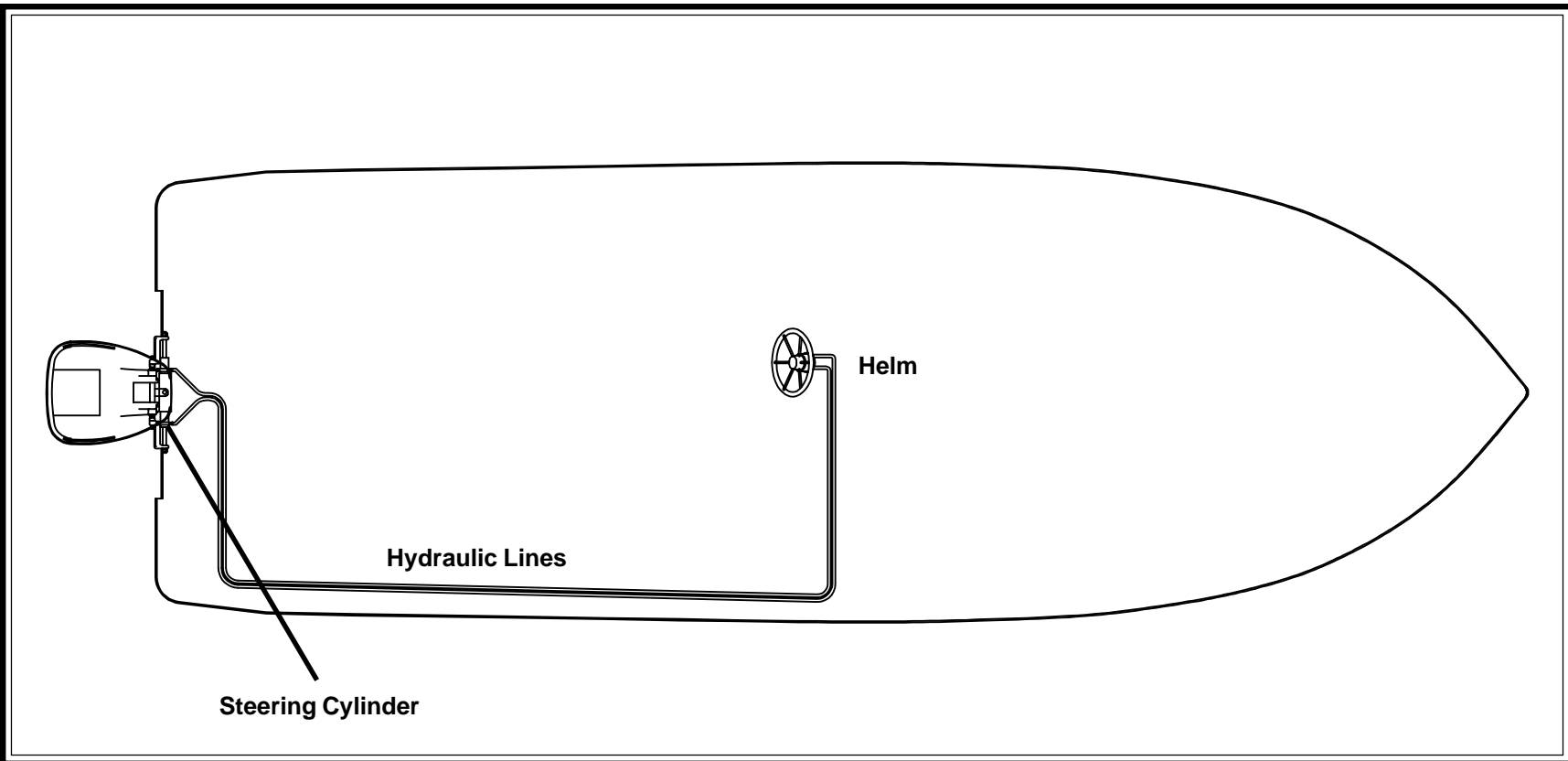

Hydraulic Steering System

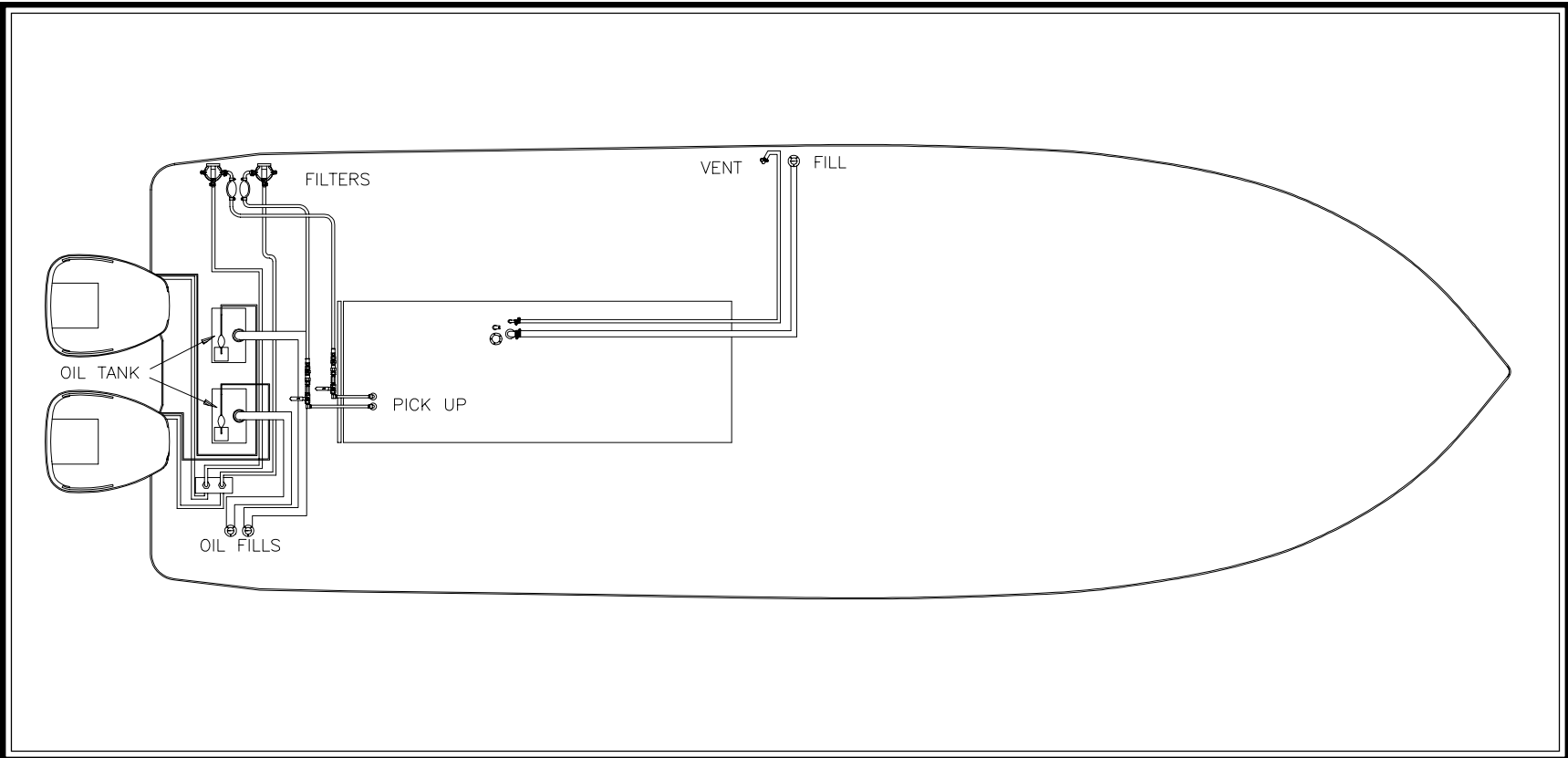

Twin Engine 2 Stroke Fuel System

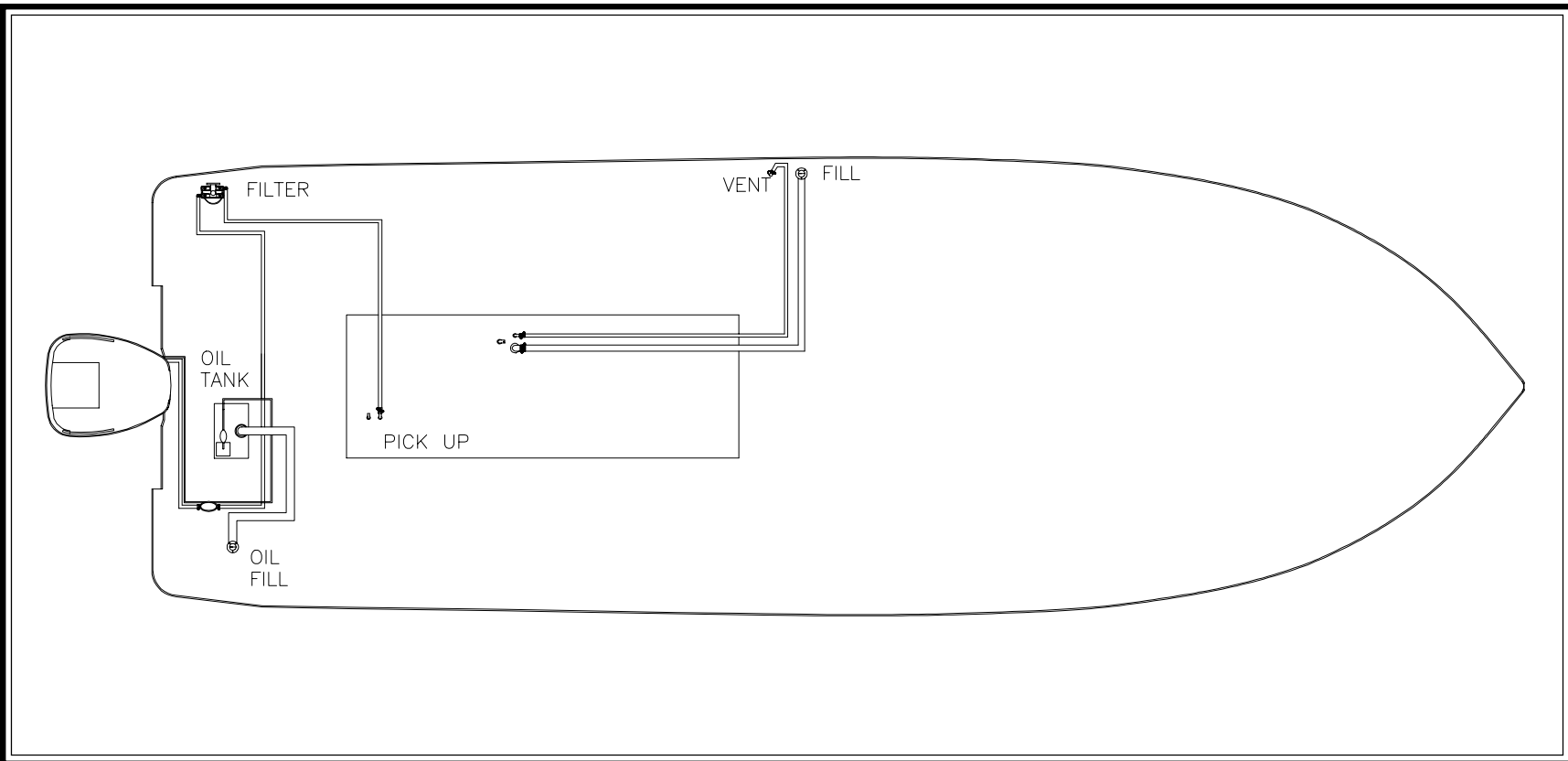

Single Engine 2 Stroke Fuel System

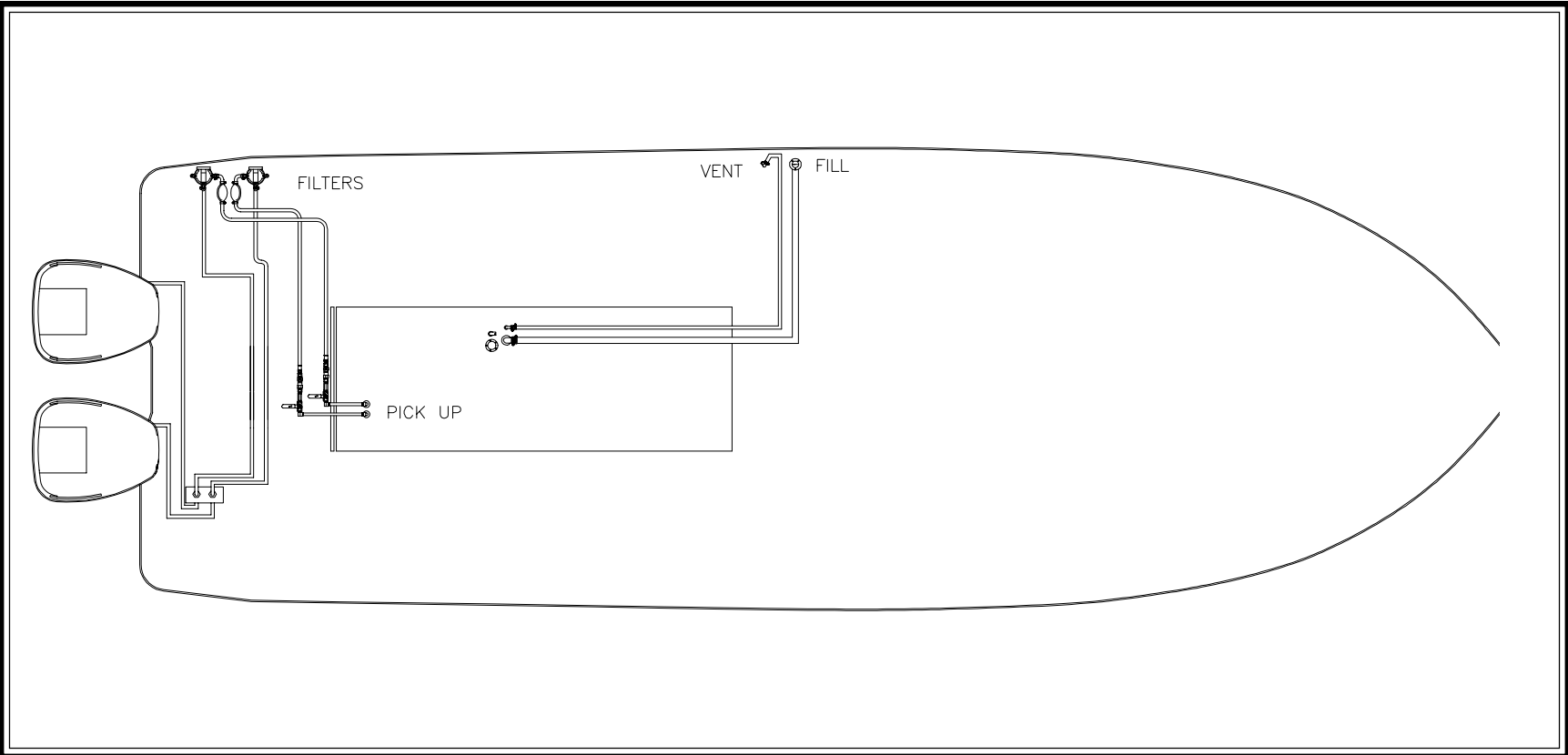

Twin Engine 4 Stroke Fuel System

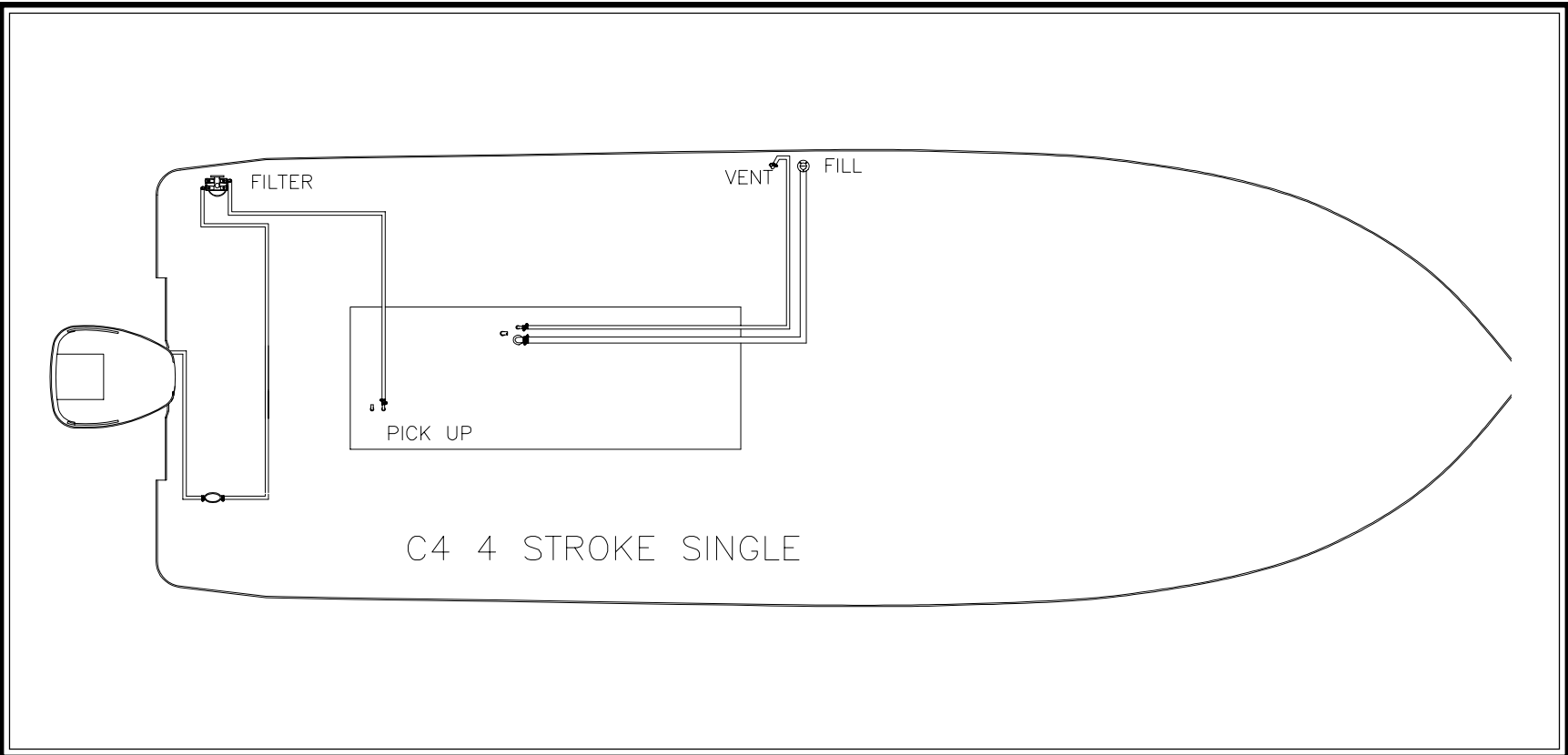

Single Engine 4 Stroke Fuel System

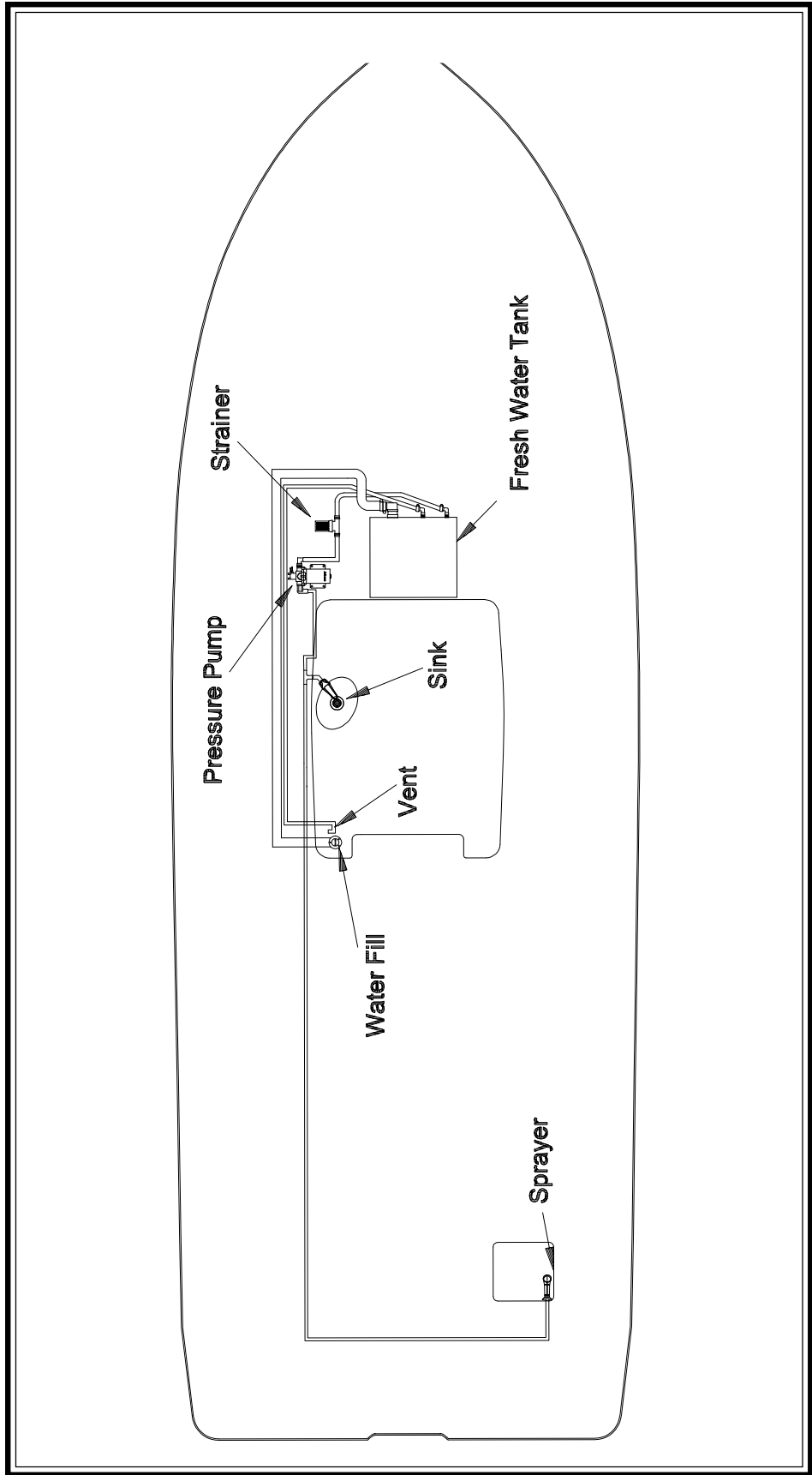

Freshwater System

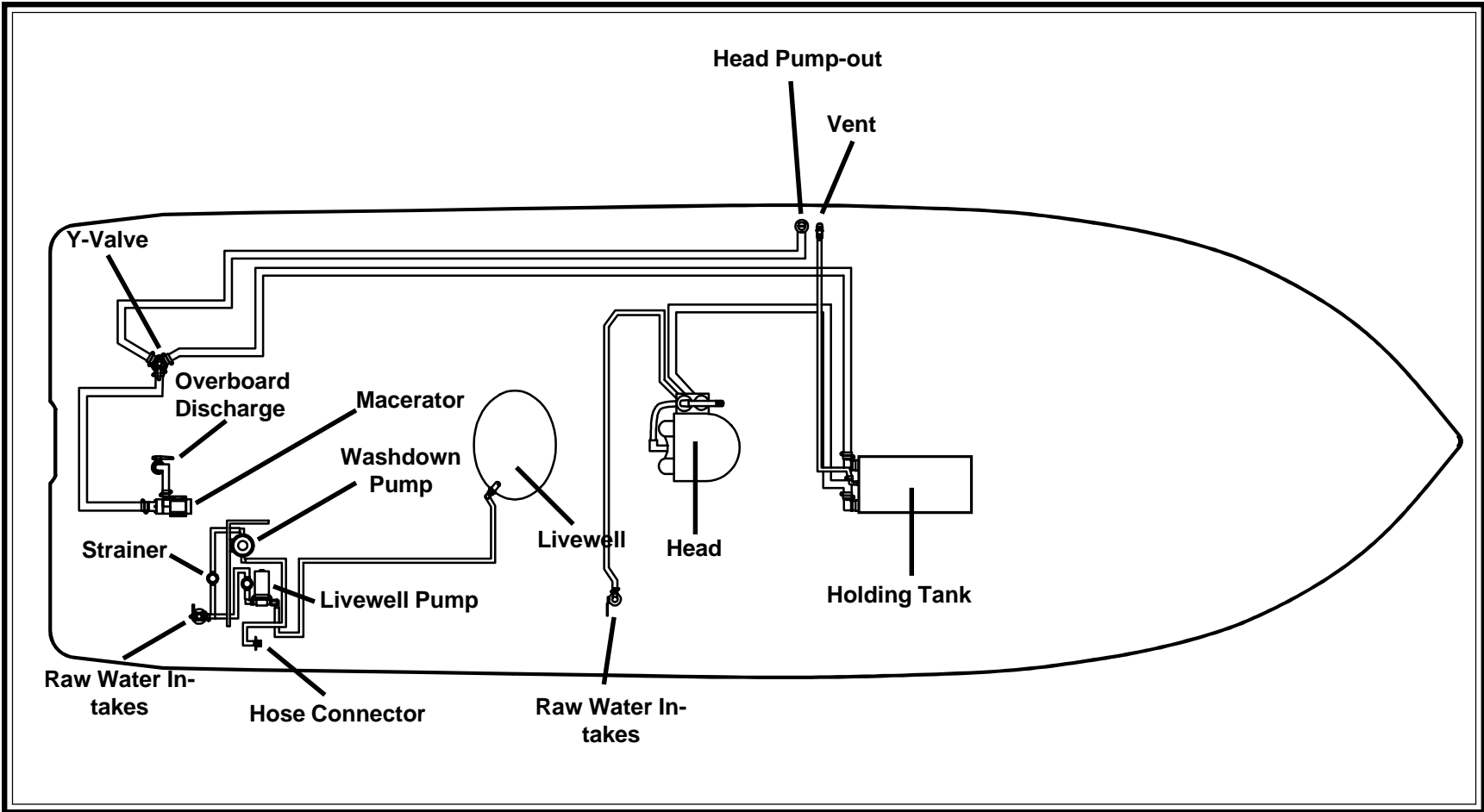

Raw Water System - Macerator

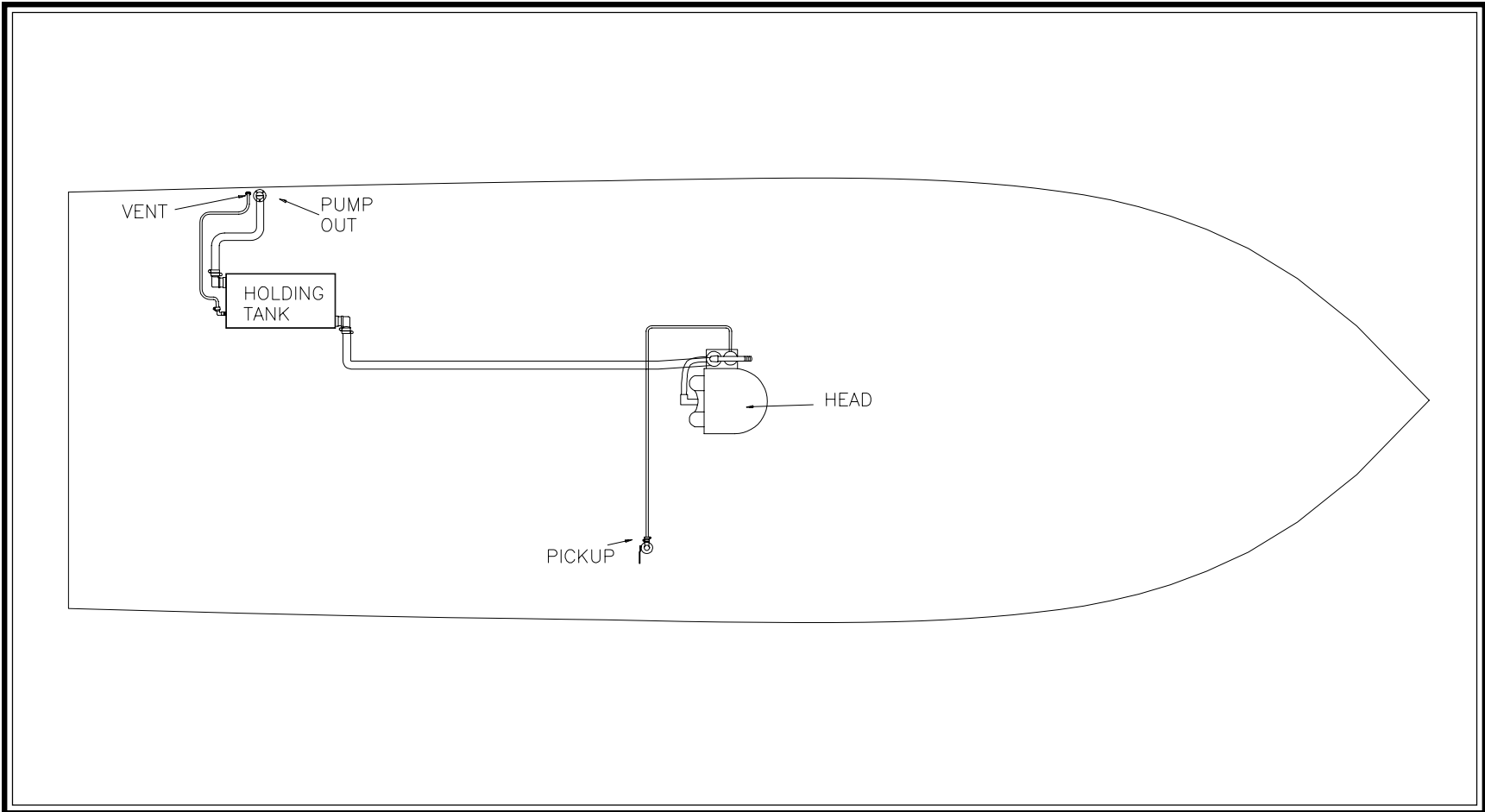

Holding System - Without Macerator

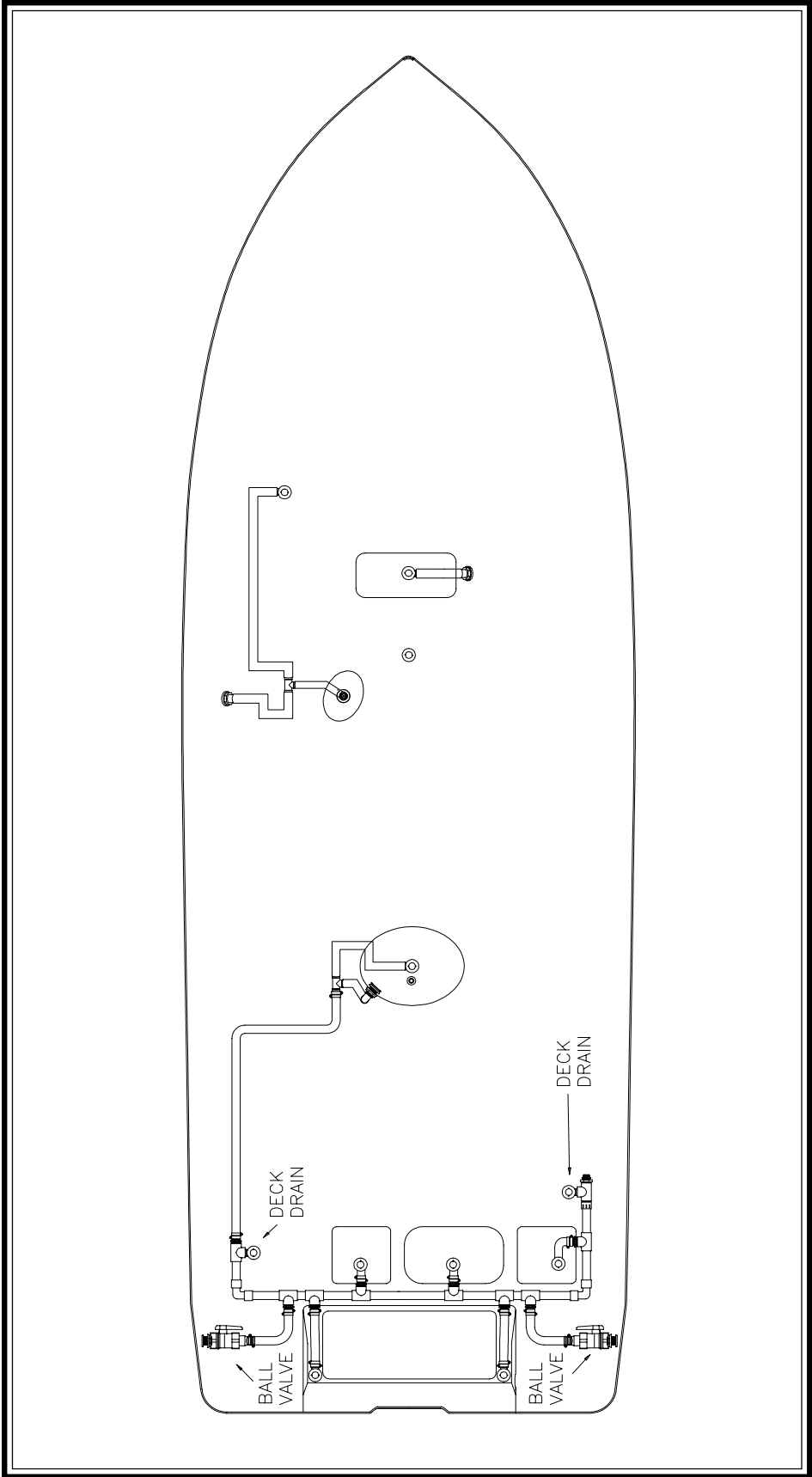

Drainage System

**THIS PAGE WAS LEFT BLANK
INTENTIONALLY**

Appendix A:

GLOSSARY OF TERMS

Aft: In, near, or toward the stern of a boat.

Aground: A boat stuck on the bottom.

Amidships: In or toward the part of a boat midway between the bow and stern.

Anchor: A specially shaped heavy metal device designed to dig efficiently into the bottom under a body of water and hold a boat in place.

Anchorage: An area specifically designated by governmental authorities in which boats may anchor.

Ashore: On shore.

Astern: Behind the boat, to move backwards.

Athwartship: At right angles to the center line of the boat.

Barnacles: Small, hard-shelled marine animals which are found in salt water attached to pilings, docks and bottoms of boats.

Beam: The breadth of a boat usually measured at its widest part.

Bearing: The direction of an object from the boat, either relative to the boat's direction or to compass degrees.

Berth: A bunk or a bed on a boat.

Bilge: The bottom of the boat below the flooring.

Bilge Pump: A pump that removes water that collects in the bilge.

Boarding: Entering or climbing into a boat.

Boarding Ladder: Set of steps temporarily fitted over the side of a boat to assist persons coming aboard.

Boat Hook: Short shaft of wood or metal with a hook fitting at one end shaped to aid in extending one's reach from the side of the boat.

Bow: The front end of a boat's hull.

Bow Line: A line that leads forward from the bow of the boat.

Bow Rail: Knee high rails of solid tubing to aid in preventing people from falling overboard.

Bridge: The area from which a boat is steered and controlled.

Bridge Deck: A Deck forward and usually above the cockpit deck.

Broach: When the boat is sideways to the seas and in danger of capsizing, a very dangerous situation that should be avoided.

Bulkhead: Vertical partition or wall separating compartments of a boat.

Cabin: Enclosed superstructure above the main deck level.

Capsize: When a boat lays on its side or turns over.

Chock: A deck fitting, usually of metal, with inward curving arms through which mooring or anchor lines are passed so as to lead them in the proper direction both on board and off the boat.

Cleat: A deck fitting, usually of metal with projecting arms used for securing anchor and mooring lines.

Closed Cooling System: A separate supply of freshwater that is used to cool the engine and circulates only within the engine.

Coaming: A vertical piece around the edges of cockpit, hatches, etc. to stop water on deck from running below.

Cockpit: An open space, usually in the aft deck, outside of the cabin.

Companionway: Opening in the deck of a boat to provide access below.

Compartment: The interior of a boat divided off by bulkheads.

Cradle: A framework designed to support a boat as she is hauled out or stored.

Cutlass Bearing: A rubber bearing in the strut that supports the propeller shaft.

D**eck:** The floor-like platform of a boat that covers the hull.

Displacement: The volume of water displaced by the hull. The displacement weight is the weight of this volume of water.

Draft: The depth of water a boat needs to float.

Dry Rot: A fungus attack on wood areas.

Dry-dock: A dock that can be pumped dry during boat construction or repair.

E**lectrical Ground:** A connection between an electrical connector and the earth.

Engine Beds: Sturdy structural members running fore and aft on which the inboard engines are mounted.

EPIRB: Emergency Position Indicating Radio Beacon. Operates as a part of a worldwide satellite distress system.

Even Keel: When a boat floats properly as designed.

F**athom:** A measure of depth. One Fathom = 6 feet.

Fender: A soft object of rubber or plastic used to protect the topsides from scarring and rubbing against a dock or another vessel.

Fend off: To push or hold the boat off from the dock or another boat.

Flying Bridge: A control station above the level of the deck or cabin.

Flukes: The broad portions of an anchor which dig into the ground.

Fore: Applies to the forward portions of a boat near the bow.

Foundering: When a boat fills with water and sinks.

Freeboard: The height from the waterline to the lowest part of the deck.

G**alley:** The kitchen of a boat.

Grab Rail: Hand-hold fittings mounted on cabin tops or sides for personal safety when moving around the boat, both on deck and below.

Ground Tackle: A general term including anchors, lines, and other gear used in anchoring.

Grounds: A boat touches the bottom.

Gunwale: The upper edge of a boat's side.

Hand Rail: Rail mounted on the boat, for grabbing with your hand, to steady you while walking about the boat.

Harbor: An anchorage which provides reasonably good protection for a boat, with shelter from wind and sea.

Hatch: An opening in the deck with a door or lid to allow for access down into a compartment of a boat.

Head: A toilet on a boat.

Heat Exchanger: Used to transfer the heat that is picked up by the closed cooling system to the raw cooling water.

Helm: The steering and control area of a boat.

Hull: The part of the boat from the deck down.

Inboard: A boat with the engine mounted within the hull of the boat. Also refers to the center of the boat away from the sides.

Inboard/outboard: Also stern drive or I/O. A boat with an inboard engine attached to an outboard drive unit.

Keel: A plate or timber plate running lengthwise along the center of the bottom of a boat.

Knot: Unit of speed indicating nautical miles per hour. 1 knot = 1 nautical mile per hour (1.15 miles per hour). A nautical mile is equal to one minute of latitude: 6076 feet. Knots times 1.15 equals miles per hour. Miles per hour times .87 equals knots.

Lay-up: To decommission a boat for the winter (usually in northern climates).

Leeward: The direction toward which the wind is blowing.

Length On The Waterline (l.w.l.): A length measurement of a boat at the waterline from the stern to where the hull breaks the water near the bow.

Limber Hole: A passage cut into the lower edges of floors and frames next to the keel to allow bilge water to flow to the lowest point of the hull where it can be pumped overboard.

Line: The term used to describe a rope when it is on a boat.

Lists: A boat that inclines to port or starboard while afloat.

L.O.A.: Boat length overall.

Locker: A closet, chest or box aboard a boat.

Loran: An electronic navigational instrument which monitors the boat's position using signals emitted from pairs of transmitting stations.

Lunch hook: A small light weight anchor typically used instead of the working anchor. Normally used in calm waters with the boat attended.

Midships: The center of the boat.

Marina: A protected facility primarily for recreational small craft.

Marine Ways or Railways: Inclined planes at the water's edge onto which boats are hauled.

Moored: A boat secured with cables, lines or anchors.

Mooring: An anchor permanently embedded in the bottom of a harbor that is used to secure a boat.

Nautical Mile: A unit of measure equal to one minute of latitude. (6076 feet)

Nun buoy: A red or red-striped buoy of conical shape.

Outboard: A boat designed for an engine to be mounted on the transom. Also a term that refers to objects away from the center line or beyond the hull sides of a boat.

Pad Eye: A deck fitting consisting of a metal eye permanently secured to the boat.

Pier: A structure which projects out from the shoreline.

Piles or Piling: A long column driven into the bottom to which a boat can be tied.

Pitching: The fore and aft rocking motion of a boat as the bow rises and falls.

Pitch: The measure of the angle of a propeller blade. Refers to the theoretical distance the boat travels with each revolution of the propeller.

P.F.D: Personal Flotation Device.

Port: The left side of the boat when facing the bow.

Porthole (port): The opening in the side of a boat to allow the admittance of light and air.

Propeller: A device having two or more blades that is attached to the engine and used for propelling a boat.

Propeller Shaft: Shaft which runs from the back of the engine gear box, aft, through the stuffing box, shaft log, struts, and onto which the propeller is attached.

Pyrotechnic Distress Signals: Distress signals that resemble the brilliant display of flares or fireworks.

Raw Water Cooled: Refers to an engine cooling system that draws sea water in through a hull fitting or engine drive unit, circulates the water in the engine, and then discharges it overboard.

Reduction Gear: Often combined with the reverse gear so that the propeller turns at a slower rate than the engine.

Reverse Gear: Changes the direction of rotation of the propeller to provide thrust in the opposite direction for stopping the boat or giving it sternway.

Roll: A boat's sideways rotational motion in rough water.

Rope Locker: A locker, usually located in the bow of a boat, used for stowing the anchor line or chain.

Rubrail: Railing (often rubber or hard plastic) that runs along the boat's sheer to protect the hull when coming alongside docks, piers, or other boats.

Rudder: A moveable flat surface that is attached vertically at or near the stern for steering.

Sea anchor: An anchor that does not touch the bottom. Provides drag to hold the bow in the most favorable position in heavy seas.

Scupper: An opening in the hull side or transom of the boat through which water on deck or in the cockpit is drained overboard.

Seacock: Safety valves installed just inside the thru-hull fittings and ahead of the piping or hose running from the fittings.

Shaft Log: Pipe through which the propeller shaft passes.

Sheer: The uppermost edge of the hull.

Sling: A strap which will hold the boat securely while being lifted, lowered, or carried.

Slip: A boat's berth between two pilings or piers.

Sole: The deck of a cockpit or interior cabin.

Spring Line: A line that leads from the bow aft or from the stern forward to prevent the boat from moving ahead or astern.

Starboard: The right side of a boat when facing the bow.

Steerageway: Sufficient speed to keep the boat responding to the rudder or drive unit.

Stem: The vertical portion of the hull at the bow.

Stern: The rear end of a boat.

Stow: To pack away neatly.

Stringer: Longitudinal members fastened inside the hull for additional structural strength.

Strut: Mounted to the hull which supports the propeller shaft in place.

Strut Bearing: See “cutlass bearing.”

Stuffing Box: Prevents water from entering at the point where the propeller shaft passes through the shaft log.

Superstructure: Something built above the main deck level.

Swamps: When a boat fills with water from over the side.

Swimming Ladder: Much the same as the boarding ladder except that it extends down into the

water.

Taffrail: Rail around the rear of the cockpit.

Thru-hull: A fitting used to pass fluids (usually water) through the hull surface, either above or below the waterline.

Topsides: The side skin of a boat between the waterline or chine and deck.

Transom: A flat stern at right angles to the keel.

Travel Lift: A machine used at boat yards to hoist boats out of and back into the water.

Trim: Refers to the boat's angle or the way it is balanced.

Trough: The area of water between the crests of waves and parallel to them.

Twin-Screw Craft: A boat with two propellers on two separate shafts.

Underway: When a boat moves through the water.

Wake: Disrupted water that a boat leaves astern as a result of its motion.

Wash: The flow of water that results from the action of the propeller or propellers.

Waterline: The plane of a boat where the surface of the water touches the hull when it is afloat on even keel.

Watertight Bulkhead: Bulkheads secured so tightly so as not to let water pass.

Wharf: A structure generally parallel to the shore.

Working Anchor: An anchor carried on a boat for most normal uses. Refers to the anchor used in typical anchoring situations.

Windlass: A winch used to raise and lower the anchor.

Windward: Toward the direction from which the wind is coming.

Yacht Basin: A protected facility primarily for recreational small craft.

Yaw: When a boat runs off her course to either side.

BOATING ACCIDENT REPORT

| | | | | | |
|---|---------|-----------------------------|---|--|---|
| If more than 3 fatalities and/or injuries, attach additional form(s) | | | | | |
| DECEASED | | | | | |
| NAME | ADDRESS | DATE OF BIRTH | WAS VICTIM? <input type="checkbox"/> Swimmer <input type="checkbox"/> Non Swimmer | DEATH CAUSED BY <input type="checkbox"/> Drowning <input type="checkbox"/> Other <input type="checkbox"/> DISAPPEARANCE | WAS PFD WORN? <input type="checkbox"/> Yes <input type="checkbox"/> No What Type? |
| NAME | ADDRESS | DATE OF BIRTH | WAS VICTIM? <input type="checkbox"/> Swimmer <input type="checkbox"/> Non Swimmer | DEATH CAUSED BY <input type="checkbox"/> Drowning <input type="checkbox"/> Other <input type="checkbox"/> DISAPPEARANCE | WAS PFD WORN? <input type="checkbox"/> Yes <input type="checkbox"/> No What Type? |
| NAME | ADDRESS | DATE OF BIRTH | WAS VICTIM? <input type="checkbox"/> Swimmer <input type="checkbox"/> Non Swimmer | DEATH CAUSED BY <input type="checkbox"/> Drowning <input type="checkbox"/> Other <input type="checkbox"/> DISAPPEARANCE | WAS PFD WORN? <input type="checkbox"/> Yes <input type="checkbox"/> No What Type? |
| INJURED | | | | | |
| NAME | ADDRESS | DATE OF BIRTH | NATURE OF INJURY | MEDICAL TREATMENT | |
| NAME | ADDRESS | DATE OF BIRTH | NATURE OF INJURY | MEDICAL TREATMENT | |
| NAME | ADDRESS | DATE OF BIRTH | NATURE OF INJURY | MEDICAL TREATMENT | |
| ACCIDENT DESCRIPTION | | | | | |
| DESCRIBE WHAT HAPPENED (Sequence of events. Include Failure of Equipment. If diagram is needed, attach separately. Continue on additional sheets if necessary. Include any information regarding the involvement of alcohol and/or drugs in causing or contributing to the accident. Include any descriptive information about the use of PFD's.) | | | | | |
| VESSEL NO. 2 (if more than 2 vessels, attach additional form (s)) | | | | | |
| Name of Operator | Address | | | Boat Number | |
| Telephone Number | | | | Boat Name | |
| Name of Owner | Address | | | | |
| WITNESSES | | | | | |
| Name | Address | | | Telephone Number | |
| Name | Address | | | Telephone Number | |
| Name | Address | | | Telephone Number | |
| WITNESSES | | | | | |
| SIGNATURE | Address | | | Telephone Number | |
| QUALIFICATION (Check One) <input type="checkbox"/> Operator <input type="checkbox"/> Owner <input type="checkbox"/> Investigator <input type="checkbox"/> Other | | | | Date Submitted | |
| (do not use) - FOR REPORTING AUTHORITY REVIEW (use agency date stamp) | | | | | |
| Causes based on (check one) <input type="checkbox"/> This report <input type="checkbox"/> Investigation and this report <input type="checkbox"/> Investigation <input type="checkbox"/> Could not be determined | | Name of Reviewing Office | | Date Received | |
| Primary Cause of Accident | | Secondary Cause of Accident | | Reviewed By | |